

User's Guide

WRE6606

Wireless AC1300 Range Extender

Default Login Details

Web Address	http://zyxelsetup (Windows) OR http://zyxelsetup.local (Mac)
LAN IP address	DHCP-assigned IP OR 192.168.1.2
Password	1234

Version 1.00 Edition 3, 09/2018

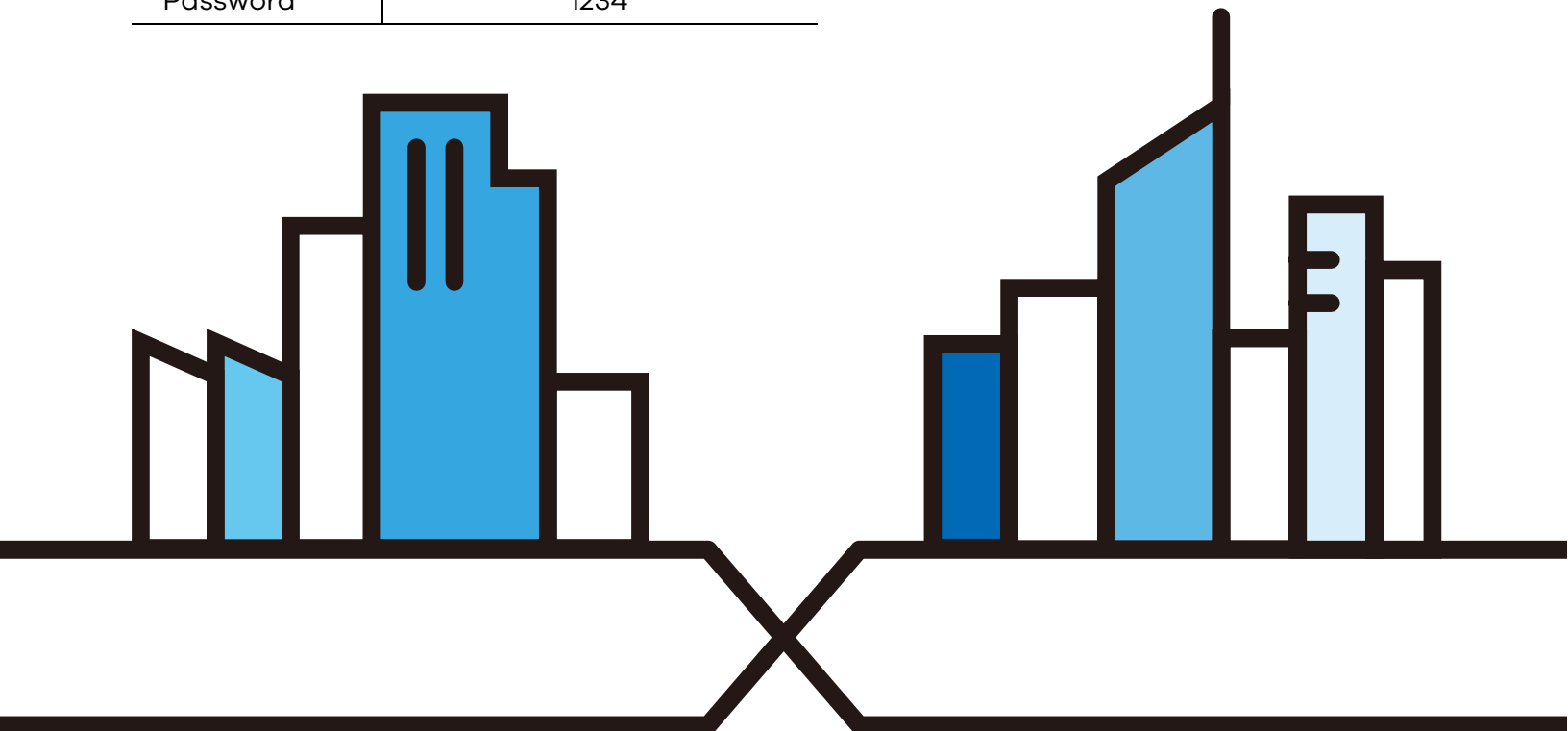

IMPORTANT!

READ CAREFULLY BEFORE USE.

KEEP THIS GUIDE FOR FUTURE REFERENCE.

Screenshots and graphics in this book may differ slightly from your product due to differences in your product firmware or your computer operating system. Every effort has been made to ensure that the information in this manual is accurate.

Related Documentation

- Quick Start Guide

The Quick Start Guide shows how to connect the WRE6606 and access the Web Configurator.

- More Information

Go to support.zyxel.com to find other information on the WRE6606.



Contents Overview

User's Guide	8
Introduction	9
The Web Configurator	13
WRE6606 Modes	18
Access Point Mode	20
Client Mode	26
Repeater Mode	30
eaZy123 Wizard Setup	36
Tutorials	44
Technical Reference	53
Monitor	54
Wireless LAN	56
LAN	78
One Connect	80
Maintenance	82
Troubleshooting	93

Table of Contents

Contents Overview	3
Table of Contents	4
Part I: User's Guide.....	8
Chapter 1	
Introduction.....	9
1.1 Overview	9
1.2 Securing the WRE6606	9
1.3 Front Panel	10
1.4 WPS Button	12
1.4.1 Wi-Fi Protected Setup	12
Chapter 2	
The Web Configurator.....	13
2.1 Overview	13
2.2 Accessing the Web Configurator	13
2.2.1 Login Screen	13
2.2.2 Password Screen	14
2.2.3 Home Screen	15
2.3 Navigating the Web Configurator	16
2.3.1 Title Bar	17
2.3.2 Navigation Panel	17
Chapter 3	
WRE6606 Modes	18
3.1 Overview	18
3.1.1 Device Modes	18
Chapter 4	
Access Point Mode.....	20
4.1 Overview	20
4.2 What You Can Do	20
4.3 What You Need to Know	20
4.3.1 Setting your WRE6606 to AP Mode	21
4.3.2 Configuring your WLAN, LAN and Maintenance Settings	21
4.4 AP Mode Status Screen	21

4.4.1 Navigation Panel	23
Chapter 5	
Client Mode	26
5.1 Overview	26
5.2 What You Can Do	26
5.3 What You Need to Know	26
5.3.1 Setting your WRE6606 to Client Mode	26
5.4 Client Mode Status Screen	27
5.4.1 Navigation Panel	28
Chapter 6	
Repeater Mode	30
6.1 Overview	30
6.2 What You Can Do	30
6.3 What You Need to Know	31
6.3.1 Setting your WRE6606 to Repeater Mode	31
6.3.2 Configuring your WLAN, LAN and Maintenance Settings	31
6.4 Repeater Mode Status Screen	31
6.4.1 Navigation Menus	34
Chapter 7	
eaZy123 Wizard Setup	36
7.1 Overview	36
7.2 Use the WRE6606 as a Repeater	36
7.3 Use the WRE6606 as an AP	39
7.4 Use the WRE6606 as a Wireless Client	41
Chapter 8	
Tutorials	44
8.1 Overview	44
8.2 Connecting to the Internet from an Access Point	44
8.3 Connecting to the WRE6606's Wireless Network Using WPS	44
8.3.1 Push Button Configuration (PBC)	45
8.3.2 PIN Configuration	46
8.4 Connecting the WRE6606 (in Repeater Mode) to an AP	47
8.4.1 Selecting an AP from an Automatically Detected List	48
8.4.2 Selecting an AP by Manually Entering Security Information	49
8.5 Connecting the WRE6606 (in Client Mode) to an AP or Wireless Router	51
Part II: Technical Reference	53

Chapter 9	
Monitor	54
9.1 Overview	54
9.2 What You Can Do	54
9.3 Packet Statistics Screen	54
Chapter 10	
Wireless LAN	56
10.1 Overview	56
10.2 What You Can Do	56
10.3 What You Should Know	56
10.3.1 Wireless Security Overview	57
10.3.2 Guest WLAN	58
10.4 General Wireless LAN Screen	58
10.5 Wireless Security	61
10.5.1 No Security	61
10.5.2 WEP Encryption	62
10.5.3 WPA-PSK/WPA2-PSK	64
10.6 AP Select Screen	65
10.7 MAC Filter	69
10.8 Wireless LAN Advanced Screen	70
10.9 Quality of Service (QoS) Screen	71
10.10 WPS Screen	71
10.11 WPS Device Screen	73
10.12 Scheduling Screen	74
10.13 Guest WLAN Screen	75
Chapter 11	
LAN	78
11.1 Overview	78
11.2 LAN IP Screen	78
Chapter 12	
One Connect	80
12.1 Overview	80
12.1.1 What You Can Do	80
12.2 One Connect Screen	80
Chapter 13	
Maintenance	82
13.1 Overview	82
13.2 What You Can Do	82
13.3 General	82

13.4 System Password Screen	83
13.5 Time Screen	83
13.6 Firmware Upgrade Screen	85
13.7 Backup / Restore Screen	87
13.7.1 Backup Configuration	88
13.7.2 Restore Configuration	88
13.7.3 Back to Factory Defaults	89
13.8 Restart Screen	89
13.9 System Mode	89
13.9.1 Repeater Broadcasting Behavior	90
Chapter 14	
Troubleshooting.....	93
14.1 Power, Hardware Connections, and LEDs	93
14.2 WRE6606 Access and Login	94
14.3 Internet Access	95
14.4 Wireless Problems	96
14.5 Resetting the WRE6606 to Its Factory Defaults	97
Appendix A Customer Support	98
Appendix B Legal Information	104
Index	111

PART I

User's Guide

CHAPTER 1

Introduction

1.1 Overview

The WRE6606 is an access point and can also act as a wireless repeater or wireless client. When the WRE6606 works as a repeater, it allows you to easily extend existing IEEE 802.11 a/b/g/n/ac wireless networks fast and easy. Simply plug the WRE6606 directly into a power outlet and the LED signal strength indicator allows you to determine the ideal installation location. See [Chapter 3 on page 18](#) for more information about the WRE6606's operating modes.

You can create the following connections using the WRE6606 in either AP or repeater mode:

- **LAN.** You can connect network devices via the Ethernet port of the WRE6606 so that they can communicate with each other and access the Internet.
- **WLAN.** Wireless clients can connect to the WRE6606 to access network resources.

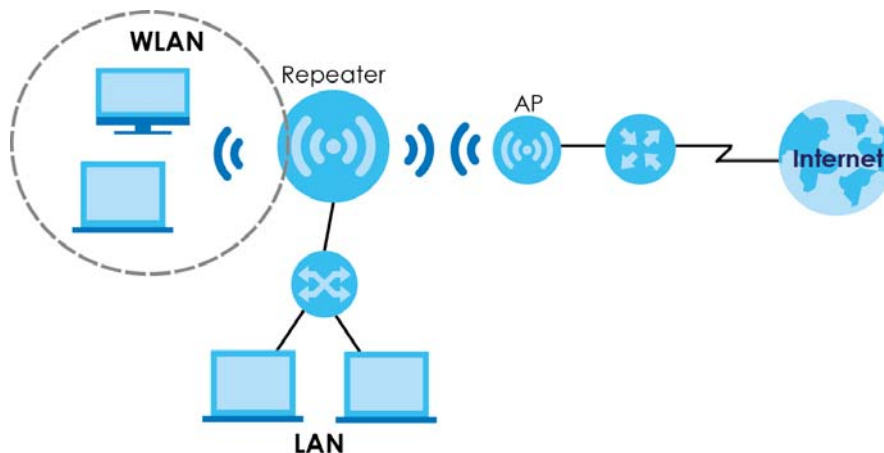

Also, the WRE6606 can elevate your network experiences with dual band and Wi-Fi Multimedia (WMM). You could use the 2.4GHz band for regular Internet surfing and downloading while using the 5GHz band for time sensitive traffic, such as high-definition video streaming, and big size file transfers. With WMM, it can automatically prioritize different types of network traffics to reach optimal performance.

Use a (supported) web browser to manage the WRE6606.

1.2 Securing the WRE6606

Do the following things regularly to make the WRE6606 more secure and to manage the WRE6606 more effectively.

- Change the password. Use a password that's not easy to guess and that consists of different types of characters, such as numbers and letters.

- Write down the password and put it in a safe place.
- Back up the configuration (and make sure you know how to restore it). Restoring an earlier working configuration may be useful if the device becomes unstable or even crashes. If you forget your password, you will have to reset the WRE6606 to its factory default settings. If you backed up an earlier configuration file, you would not have to totally re-configure the WRE6606. You could simply restore your last configuration.

1.3 Front Panel

Figure 1 Front Panel

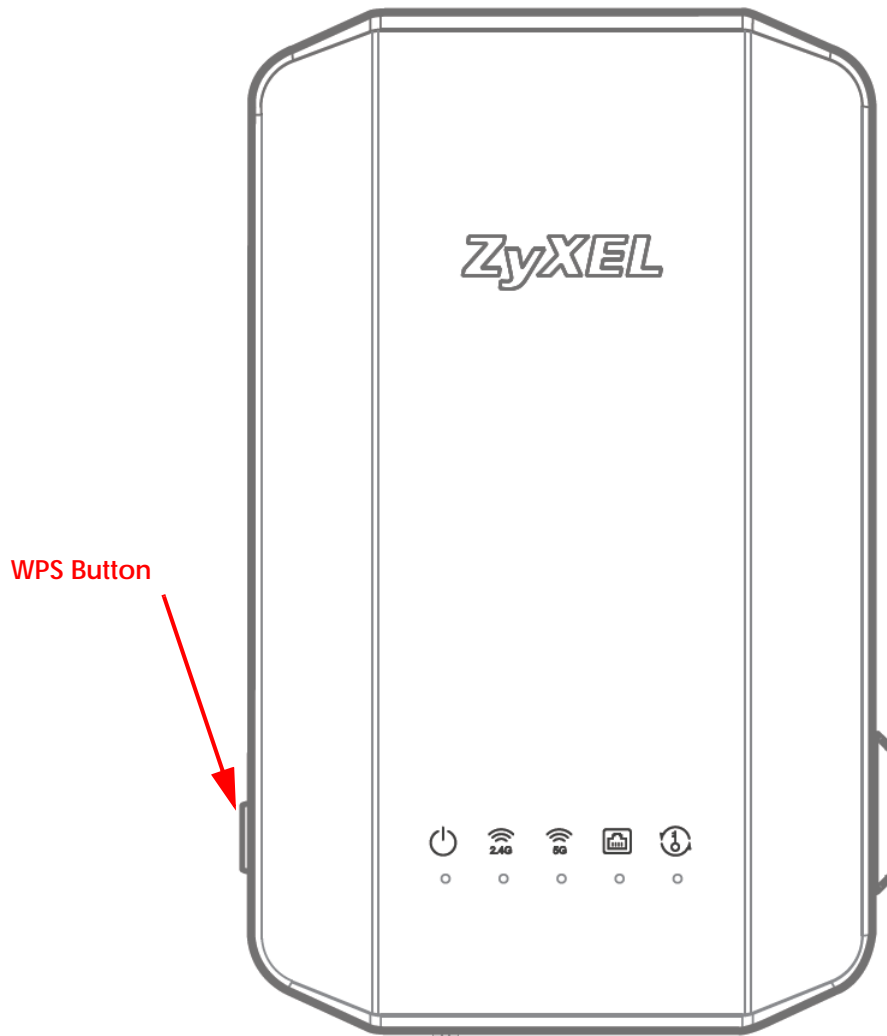

The following table describes the LEDs.

Table 1 Front Panel LEDs

LED	COLOR	STATUS	DESCRIPTION
Power	Green	On	The WRE6606 is receiving power and functioning properly.
		Blinking	The WRE6606 is booting, resetting to factory defaults or firmware upgrade is in progress.
		Off	The WRE6606 is not receiving power.
2.4G	Green	On	In AP mode, it means WLAN signal is detected.
		Blinking	In AP mode, Client mode, and Repeater mode, it signifies data is transmitting. Different LED colors indicate the Wi-Fi signal strength. <ul style="list-style-type: none"> • Green: signifies a signal strength of 50% ~ 100% • Orange: signifies a signal strength of 21% ~ 49% • Red: signifies a signal strength under 20%
		Off	In AP mode, Client mode, and Repeater mode, the 2.4 GHz wireless LAN is not enabled. There is no signal detected or the WRE6606 is not connected to a wireless router/AP, or the LEDs are turned off using the WPS button.
5G	Green	On	In AP mode, it means WLAN signal is detected.
		Blinking	In AP mode, Client mode, and Repeater mode, it signifies data is transmitting. Different LED colors indicate the Wi-Fi signal strength. <ul style="list-style-type: none"> • Green: signifies a signal strength of 50% ~ 100% • Orange: signifies a signal strength of 21% ~ 49% • Red: signifies a signal strength under 20%
		Off	In AP mode, Client mode, and Repeater mode, the 5 GHz wireless LAN is not enabled. There is no signal detected or the WRE6606 is not connected to a wireless router/AP, or the LEDs are turned off using the WPS button.
LAN	Green/ Orange	On	LAN connection is successful.
		Blinking	Data is transmitting.
		Off	LAN connection is off.
			Different LED colors indicate the Ethernet transfer speed. <ul style="list-style-type: none"> • Green: signifies the Ethernet speed has reached 1000 Mbps. • Orange: signifies the Ethernet speed has reached 10/100 Mbps.
WPS	Green	On	This remains on for 5 minutes after a successful WPS connection has been established.
		Blinking	The WPS connection is in progress and the WRE6606 is waiting for another WPS device to connect.
		Off	The WPS connection has failed or was established more than 5 minutes ago.

1.4 WPS Button

The WPS button can be used to begin Wi-Fi Protected Setup (WPS), reboot the WRE6606 while keeping its configuration or reset the WRE6606 to factory default configuration.

Table 2 WPS Button Functions

ACTION	RESULT
Press three times within 5 seconds	Turn off or turn on all LEDs.
AP Mode	
Push the WPS button once	The WRE6606 begins connecting to a wireless client via WPS. See Section 1.4 on page 12 .
Hold for 5 to 10 seconds	The WRE6606 keeps its configuration and reboots.
Hold for more than 10 seconds	The WRE6606 resets its configuration to factory defaults and reboots. Also, the power LED will be blinking. See Section 14.5 on page 97 .
Repeater Mode	
Push the WPS button once	The WRE6606 begins connecting to the upper router via WPS.
Push twice within 5 seconds	The WRE6606 begins connecting to a wireless client via WPS. See Section 1.4 on page 12 .
Hold for 5 to 10 seconds	The WRE6606 keeps its configuration and reboots.
Hold for more than 10 seconds	The WRE6606 resets its configuration to factory defaults and reboots. Also, the power LED will be blinking. See Section 14.5 on page 97 .
Client Mode	
Push the WPS button once	The WRE6606 begins connecting to an access point via WPS.
Hold for 5 to 10 seconds	The WRE6606 keeps its configuration and reboots.
Hold for more than 10 seconds	The WRE6606 resets its configuration to factory defaults and reboots. Also, the power LED will be blinking. See Section 14.5 on page 97 .

1.4.1 Wi-Fi Protected Setup

Your WRE6606 supports Wi-Fi Protected Setup (WPS), which is an easy way to set up a secure wireless network. WPS is an industry standard specification, defined by the Wi-Fi Alliance.

WPS allows you to quickly set up a wireless network with strong security, without having to configure security settings manually. Each WPS connection works between two devices. Both devices must support WPS (check each device's documentation to make sure).

Depending on the devices you have, you can either press a button (recommended) on the device itself, or in its configuration utility or enter a PIN (a unique Personal Identification Number that allows one device to authenticate the other) in each of the two devices. When WPS is activated on a device, it has two minutes to find another device that also has WPS activated. Then, the two devices connect and set up a secure network by themselves.

For more information on using WPS, see [Section 10.10 on page 71](#).

CHAPTER 2

The Web Configurator

2.1 Overview

This chapter describes how to access the WRE6606 Web Configurator and provides an overview of its screens.

The Web Configurator is an HTML-based management interface that allows easy setup and management of the WRE6606 via Internet browser. Use Internet Explorer 6.0 and later versions, Mozilla Firefox 3 and later versions, or Safari 2.0 and later versions. The recommended screen resolution is 1024 by 768 pixels.

In order to use the Web Configurator you need to allow:

- Web browser pop-up windows from your device.
- JavaScript (enabled by default).
- Java permissions (enabled by default).

Refer to [Chapter 14 Troubleshooting](#) to see how to make sure these functions are allowed in Internet Explorer.

2.2 Accessing the Web Configurator

- 1 Make sure your WRE6606 hardware is properly connected and prepare your computer or computer network to connect to the WRE6606 (refer to the Quick Start Guide).
- 2 Launch your web browser.
- 3 Open a web browser such as Internet Explorer and type "http://zyxelsetup" (Windows) or "http://zyxelsetup.local" (Mac) as the web address in your web browser.

2.2.1 Login Screen

The Web Configurator initially displays the following login screen.

Figure 2 Login Screen



The following table describes the labels in this screen.

Table 3 Login screen

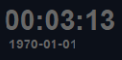
LABEL	DESCRIPTION
Password	Type "1234" (default) as the password.
Language	Select the language you want to use to configure the Web Configurator. Click Login .
	This shows the time (hh:mm) and date (yyyy:mm:dd) of the time zone you select in the Maintenance > Time screen (see Section 13.5 on page 83). The time is in 24-hour format, for example 15:00 is 3:00 PM.

2.2.2 Password Screen

You should see a screen asking you to change your password (highly recommended) as shown next.

Figure 3 Change Password Screen

Use this screen to change the password.

The Wizard setup walks you through the most common configuration settings. We suggest you use this mode if it is the first time you are setting up your router or if you need to make basic configuration changes.

Use Advanced mode if you need access to more advanced features not included in Wizard mode.



New Password:

Retype to Confirm:

The following table describes the labels in this screen.

Table 4 Change Password Screen

LABEL	DESCRIPTION
New Password	Type a new password.
Retype to Confirm	Retype the password for confirmation.
Apply	Click Apply to save your changes back to the WRE6606.
Ignore	Click Ignore if you do not want to change the password this time.

Note: Reset the WRE6606 if you forget your password or IP address, or you cannot access the Web Configurator see [Section 14.5 on page 97](#).

2.2.3 Home Screen

If you have previously logged into the Web Configurator but did not click **Logout**, you may be redirected to the **Home** screen.

You can also open this screen by clicking **Home** () in the Web Configurator screens.

The Home screen displays as follows.

Figure 4 Home Screen

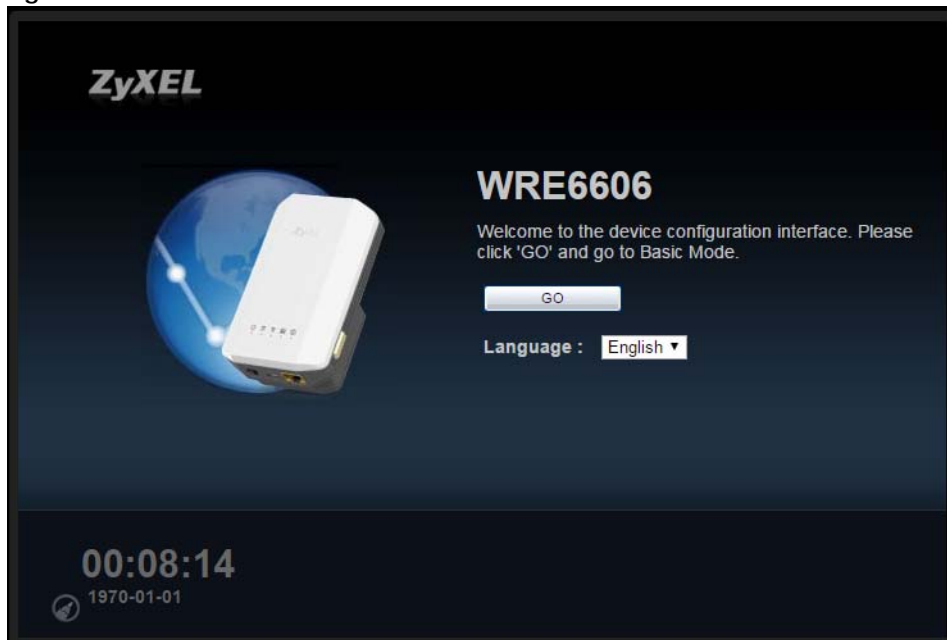

The following table describes the labels in this screen.

Table 5 Home Screen

LABEL	DESCRIPTION
GO	Click this to return to the previous screen.
Language	Select a language to go to the Web Configurator in that language and click GO .
 00:08:14 1970-01-01	(This is just an example). This shows the time (hh:mm:ss) and date (yyyy:mm:dd) of the time zone you select in Section 2.2.3.1 on page 16 or Section 13.5 on page 83 .

2.2.3.1 Time/Date Edit

One time zone can cover more than one country. You can choose a particular country in which the WRE6606 is located and have the WRE6606 display and use the current time and date for its logs.

Click the  icon to change the time and date display.

Figure 5 Change Time Zone



The following table describes the labels in this screen.

Table 6 Change Time Zone

LABEL	DESCRIPTION
Change time zone	Select the specific country whose current time and date you want the WRE6606 to display.
Finish	Click this to apply the settings and refresh the weather display.

2.3 Navigating the Web Configurator

The following summarizes how to navigate the web configurator from the **Status** screen.

Figure 6 The Web Configurator's Main Screen

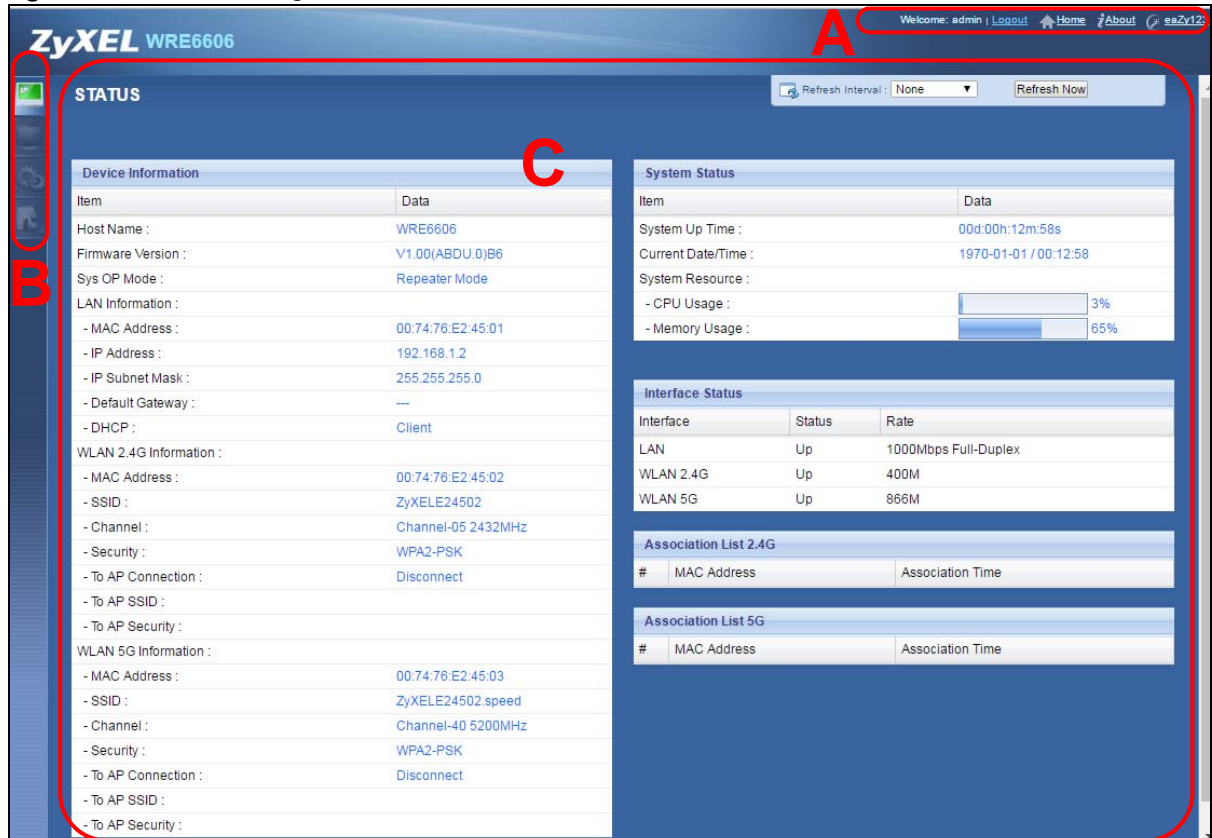

The Web Configurator's main screen is divided into these parts:

- **A** - Title Bar
- **B** - Navigation Panel
- **C** - Main Window

2.3.1 Title Bar

The title bar provides some useful links that always appear over the screens below, regardless of how deep into the Web Configurator you navigate.

Figure 7 Title Bar



The icons provide the following functions.

Table 7 Title Bar: Web Configurator Icons

LABEL	DESCRIPTION
Logout	Click this at any time to exit the Web Configurator.
Home	Click this to open the home screen. See Section 2.2.3 on page 15 .
About	Click this icon to view copyright and a link for related product information.
eaZy123	Click this icon to open the wizard. See Chapter 7 on page 36 .

2.3.2 Navigation Panel

Use the menu items on the navigation panel to open screens to configure WRE6606 features.

The following table describes the icons shown in the navigation panel.

Table 8 Navigation Panel Menu Icons

ICON	DESCRIPTION
	Click this icon to see the Status page. The information in this screen depends on the device mode you select.
	Click this icon to see the Monitor navigation menu.
	Click this icon to see the Configuration navigation menu.
	Click this icon to see the Maintenance navigation menu.

CHAPTER 3

WRE6606 Modes

3.1 Overview

This chapter introduces the different modes available on your WRE6606.

- **System mode:** This is the operating mode of your WRE6606, or simply how the WRE6606 is being used in the network.

3.1.1 Device Modes

This refers to the system operating mode of the WRE6606, which can act as a:

- **Access Point:** Use this mode if you want to extend your network by allowing network devices to connect to the WRE6606 wirelessly. Go to [Section 4.4 on page 21](#) to view the **Status** screen in this mode.
In this mode, you can also set the WRE6606 to work as an AP only, a wireless bridge to establish wireless links with other APs (WDS bridge), or an AP and bridge simultaneously (WDS repeater). See [Section 4.2 on page 20](#) for more information.
- **Client:** Use this mode if there is an existing wireless router or access point in the network to which you want to connect your local network. Go to [Section 5.4 on page 27](#) to view the **Status** screen in this mode. In Client mode, you should know the SSID and wireless security details of the access point to which you want to connect.
- **Repeater:** In this mode, the WRE6606 can be an access point and a wireless client at the same time. Go to [Section 6.4 on page 31](#) to view the **Status** screen in this mode. Use this mode if there is an existing wireless router or access point in your network and you also want to allow clients to connect to the WRE6606 wirelessly.

The following figure is an illustration of the device configuration modes of the WRE6606.

Figure 8 System Operating Mode Example

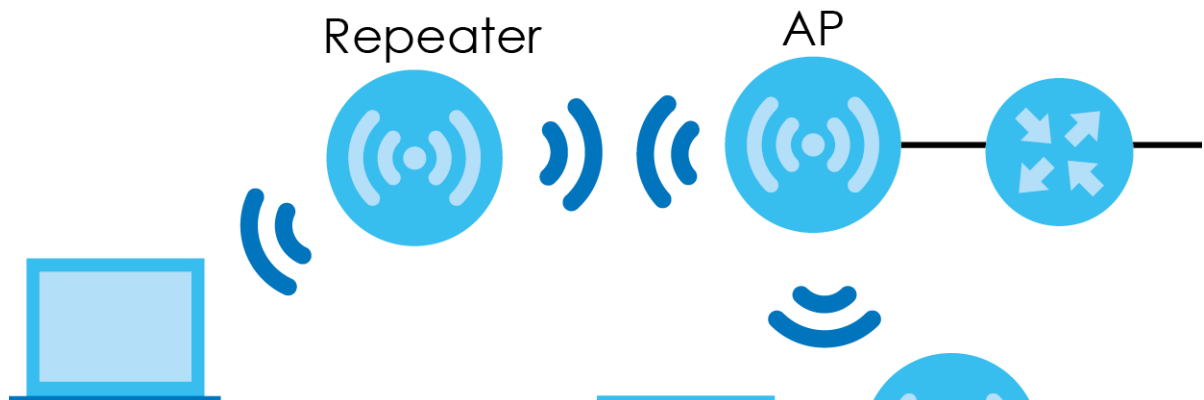

Note: Choose your device mode carefully to avoid having to change it later.

Under Repeater mode, the WRE6606 supports three WPS behaviors: Normal mode, Range boost mode, and Speed boost mode. These behaviors are only available in Repeater mode through the **Maintenance** screen.

3.1.1.1 Changing Operating Mode

Push the **AP (A)/Client (C)/Repeater (R)** mode switch on the WRE6606's side panel to the **AP** position to have the WRE6606 act as an access point. Push the switch to the **Client** position to have the WRE6606 work as a wireless client. Push the switch to the **Repeater** position to have the WRE6606 work as a universal repeater.

The WRE6606 restarts automatically after you change operating modes.

CHAPTER 4

Access Point Mode

4.1 Overview

In Access Point (AP) mode your WRE6606 bridges a wired network (LAN) and wireless LAN (WLAN) in the same subnet. See the figure below for an example.

Figure 9 Access Point Mode

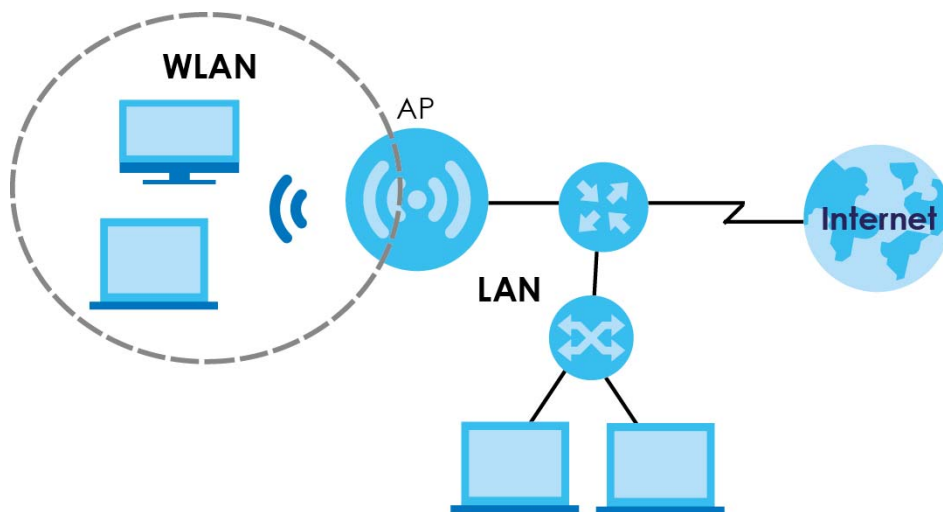

Note: See [Chapter 8 on page 44](#) for an example of setting up a wireless network in Access Point mode.

4.2 What You Can Do

- Use the **Status** screen ([Section 4.4 on page 21](#)) to view read-only information about your WRE6606.
- Use the **LAN** screen ([Chapter 11 on page 78](#)) to set the IP address for your WRE6606 acting as an access point.
- Use the **Wireless LAN** screens ([Chapter 10 on page 56](#)) to configure the wireless settings and wireless security between the wireless clients and the WRE6606.

4.3 What You Need to Know

With the exception of the **Scheduling** and **Guest WLAN** screens, other configuration screens in Access Point mode are similar to the ones in repeater mode. See [Chapter 3 on page 18](#) of this User's Guide.

4.3.1 Setting your WRE6606 to AP Mode

By default, AP mode in the WRE6606 is not configured with a static IP address. To setup your WRE6606 in AP mode for the first time, the directly-connected router must have the DHCP server function enabled.

- 1 To use your WRE6606 as an access point, See [Section 3.1.1.1 on page 19](#).
- 2 Connect one end of an Ethernet cable to the Ethernet port on the WRE6606 and the other end to your router.
- 3 Connect your computer to your network, make sure both the WRE6606 and computer are under the same subnet.
- 4 Open a web browser window and type "http://zyxelsetup" in the web address. The login screen displays.
- 5 Enter "1234" (default) as the password and click **Login**.
- 6 Type a new password and retype it to confirm, then click **Apply**. Otherwise, click **Ignore**.

The WRE6606 Web Configurator displays, which allows you to configure the AP mode.

4.3.2 Configuring your WLAN, LAN and Maintenance Settings

- See [Chapter 10 on page 56](#) and [Chapter 11 on page 78](#) for information on configuring your wireless network and LAN settings.
- See [Chapter 13 on page 82](#) for information on configuring your Maintenance settings.

4.4 AP Mode Status Screen

Click  to open the **Status** screen.

Figure 10 Status Screen: Access Point Mode

The screenshot shows the 'STATUS' screen with the following data:

Item	Data
Host Name :	WRE6606
Firmware Version :	V1.00(ABDU.0)B6
Sys OP Mode :	AP Mode
LAN Information :	
- MAC Address :	00:74:76:E2:45:01
- IP Address :	192.168.1.2
- IP Subnet Mask :	255.255.255.0
- Default Gateway :	---
- DHCP :	Client
WLAN 2.4G Information :	
- MAC Address :	00:74:76:E2:45:02
- SSID :	ZyXELE24502
- Channel :	Channel-05 2432MHz -(Auto Channel)
- Security :	WPA2-PSK
WLAN 5G Information :	
- MAC Address :	00:74:76:E2:45:03
- SSID :	ZyXELE24502.speed
- Channel :	Channel-40 5200MHz -(Auto Channel)
- Security :	WPA2-PSK

Item	Data
System Up Time :	00d:00h:07m:00s
Current Date/Time :	1970-01-01 / 00:06:59
System Resource :	
- CPU Usage :	3%
- Memory Usage :	65%

Interface	Status	Rate
LAN	Up	1000Mbps Full-Duplex
WLAN 2.4G	Up	400M
WLAN 5G	Up	866M

#	MAC Address	Association Time

#	MAC Address	Association Time

The following table describes the labels shown in the **Status** screen.

Table 9 Status Screen: Access Point Mode

LABEL	DESCRIPTION
	Select a number of seconds or None from the drop-down list box to refresh all screen statistics automatically at the end of every time interval or to not refresh the screen statistics.
	Click this button to refresh the status screen statistics.
Device Information	
Host Name	This is the WRE6606's system name you configure in the Maintenance > General screen.
Firmware Version	This is the firmware version and the date created.
Sys OP Mode	This is the device mode (Section 3.1.1 on page 18) to which the WRE6606 is set - AP Mode .
LAN Information	
MAC Address	This shows the LAN Ethernet adapter MAC Address of your device.
IP Address	This shows the LAN port's IP address.
IP Subnet Mask	This shows the LAN port's subnet mask.
Default Gateway	This shows the LAN port's gateway IP address.
DHCP	This shows the LAN port's DHCP role - Client or None .
WLAN 2.4G Information	
MAC Address	This shows the wireless adapter MAC Address of your device.
SSID	This shows a descriptive name used to identify the WRE6606 in the wireless LAN.
Channel	This shows the channel number which you select manually or the WRE6606 automatically scans and selects.
Security	This shows the level of wireless security the WRE6606 is using.
WLAN 5G Information	

Table 9 Status Screen: Access Point Mode (continued)

LABEL	DESCRIPTION
MAC Address	This shows the wireless adapter MAC Address of your device.
SSID	This shows a descriptive name used to identify the WRE6606 in the wireless LAN.
Channel	This shows the channel number which you select manually or the WRE6606 automatically scans and selects.
Security	This shows the level of wireless security the WRE6606 is using.
System Status	
Item	This column shows the type of data the WRE6606 is recording.
Data	This column shows the actual data recorded by the WRE6606.
System Up Time	This is the total time the WRE6606 has been on.
Current Date/Time	This field displays your WRE6606's present date and time.
System Resource	
CPU Usage	This displays what percentage of the WRE6606's processing ability is currently used. When this percentage is close to 100%, the WRE6606 is running at full load, and the throughput is not going to improve anymore. If you want some applications to have more throughput, you should turn off other applications (for example, using bandwidth management).
Memory Usage	This shows what percentage of the heap memory the WRE6606 is using.
Interface Status	
Interface	This displays the WRE6606 port types. The port types are: LAN and WLAN .
Status	For the LAN port, this field displays Down (line is down) or Up (line is up or connected). For the WLAN, it displays Up when the WLAN is enabled or Down when the WLAN is disabled.
Rate	For the LAN ports, this displays the port speed and duplex setting or is left blank when the line is disconnected. For the WLAN, it displays the maximum transmission rate when the WLAN is enabled and is left blank when the WLAN is disabled.
Association List 2.4G	
#	This is the index number of an associated wireless client.
MAC Address	This field displays the MAC address of an associated wireless client.
Association Time	This field displays the time a wireless station first associated with the WRE6606's WLAN network.
Association List 5G	
#	This is the index number of an associated wireless client.
MAC Address	This field displays the MAC address of an associated wireless client.
Association Time	This field displays the time a wireless station first associated with the WRE6606's WLAN network.

4.4.1 Navigation Panel

Use the menu in the navigation panel to configure WRE6606 features in Access Point mode.

The following screen and table show the features you can configure in Access Point mode.

Figure 11 Menu: Access Point Mode



The following table describes the sub-menus.

Table 10 Navigation Panel: Access Point Mode

LINK	TAB	FUNCTION
Status	Status	This screen shows the WRE6606's general device, system and interface status information.
MONITOR		
Monitor		
Packet Statistics	Packet Statistics	Use this screen to view port status, packet specific statistics, the "system up time" and so on.
CONFIGURATION		
Network		
Wireless LAN 2.4G	General	Use this screen to configure general wireless LAN and wireless security settings.
	MAC Filter	Use this screen to configure the WRE6606 to block access to devices or block the devices from accessing the WRE6606.
	Advanced	Use this screen to configure advanced wireless settings.
	QoS	Use this screen to enable Wi-Fi MultiMedia Quality of Service (WMMQoS).
	WPS	Use this screen to enable and configure WPS.
	WPS Device	Use this screen to add a wireless station using WPS.
	Scheduling	Use this screen to schedule the times the Wireless LAN is enabled or disabled.
	Guest WLAN	Use this screen to configure multiple BSSs on the WRE6606.
Wireless LAN 5G	General	Use this screen to configure general wireless LAN settings.
	MAC Filter	Use this screen to configure the WRE6606 to block access to devices or block the devices from accessing the WRE6606.
	Advanced	Use this screen to configure advanced wireless settings.
	QoS	Use this screen to enable Wi-Fi MultiMedia Quality of Service (WMMQoS).
	WPS	Use this screen to enable and configure WPS.
	WPS Device	Use this screen to add a wireless station using WPS.
	Scheduling	Use this screen to schedule the times the Wireless LAN is enabled or disabled.
	Guest WLAN	Use this screen to configure multiple BSSs on the WRE6606.
LAN	IP	Use this screen to configure LAN IP address and subnet mask.
OneConnect	OneConnect	Use this screen to enable or disable Wi-Fi auto-configuration.
MAINTENANCE		
General	General	Use this screen to view and change administrative settings such as system and domain names.
Password	Password Setup	Use this screen to change the password of your WRE6606.
Time	Time Setting	Use this screen to change your WRE6606's time and date.

Table 10 Navigation Panel: Access Point Mode

LINK	TAB	FUNCTION
Firmware Upgrade	Firmware Upgrade	Use this screen to upload firmware to your WRE6606.
Backup Restore	Backup Restore	Use this screen to backup and restore the configuration or reset your WRE6606 to the factory defaults.
Restart	Restart	Use this screen to reboot the WRE6606 without turning the power off.

CHAPTER 5

Client Mode

5.1 Overview

Your WRE6606 can act as a wireless client. In wireless client mode, it can connect to an existing network via an access point. Use this mode if you already have an access point or wireless router in your network.

In the example below, one WRE6606 (**A**) is configured as a wireless client and another is used as an access point (**B**). The WRE6606 has two clients that need to connect to the Internet. The WRE6606 wirelessly connects to the available access point (**B**).

Figure 12 Wireless Client Mode

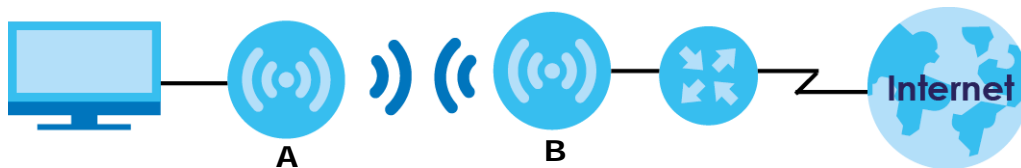

After the WRE6606 and the access point connect, the WRE6606 acquires its WAN IP address from the access point. The clients of the WRE6606 can now surf the Internet.

5.2 What You Can Do

- Use the **Status** screen ([Section 5.4 on page 27](#)) to view read-only information about your WRE6606.
- Use the **LAN** screen ([Chapter 11 on page 78](#)) to set the IP address for your WRE6606.
- Use the **Wireless LAN** screens ([Chapter 10 on page 56](#)) to associate your WRE6606 (acting as a wireless client) with an existing access point.

5.3 What You Need to Know

With the exception of the **Wireless LAN**, **LAN**, **Monitor**, **Configuration** and **Maintenance** screens, other configuration screens in Client mode are similar to the ones in Access Point Mode. See [Chapter 3 on page 18](#) of this User's Guide.

5.3.1 Setting your WRE6606 to Client Mode

- 1 To use your WRE6606 as a wireless client, see [Section 3.1.1.1 on page 19](#).
- 2 Connect your computer to the LAN port of the WRE6606.

- 3 Open a web browser such as Internet Explorer and type "http://zyxelsetup" as the web address in your web browser.
- 4 Enter "1234" (default) as the password and click **Login**.
- 5 Type a new password and retype it to confirm, then click **Apply**. Otherwise, click **Ignore**.

Note: You have to log into the Web Configurator again when you change modes. As soon as you do, your WRE6606 is already in Client mode.

Note: The client mode IP address is always the same as the access point mode IP address. If you changed the IP address of your WRE6606 while in access point mode, use this IP address in client mode.

5.4 Client Mode Status Screen

Click  to open the **Status** screen.

Figure 13 Status Screen: Client Mode

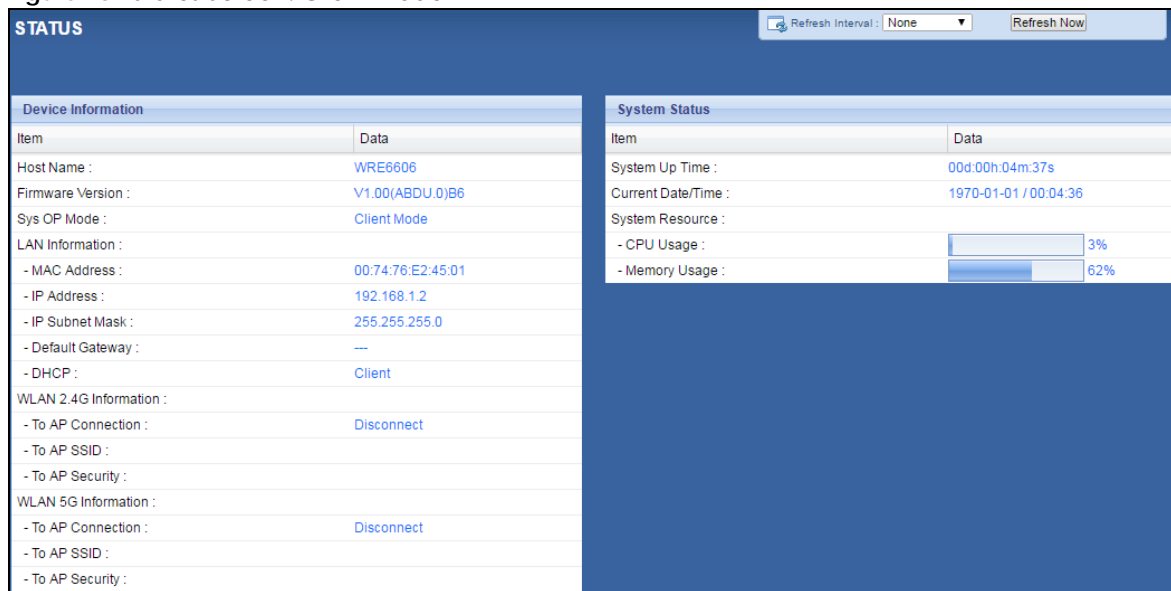

Device Information		System Status	
Item	Data	Item	Data
Host Name :	WRE6606	System Up Time :	00d:00h:04m:37s
Firmware Version :	V1.00(ABDU.0)B6	Current Date/Time :	1970-01-01 / 00:04:36
Sys OP Mode :	Client Mode	System Resource :	
LAN Information :		- CPU Usage :	3%
- MAC Address :	00:74:76:E2:45:01	- Memory Usage :	62%
- IP Address :	192.168.1.2		
- IP Subnet Mask :	255.255.255.0		
- Default Gateway :	---		
- DHCP :	Client		
WLAN 2.4G Information :			
- To AP Connection :	Disconnect		
- To AP SSID :			
- To AP Security :			
WLAN 5G Information :			
- To AP Connection :	Disconnect		
- To AP SSID :			
- To AP Security :			

The following table describes the labels shown in the **Status** screen.

Table 11 Status Screen: Access Point Mode

LABEL	DESCRIPTION
	Select a number of seconds or None from the drop-down list box to refresh all screen statistics automatically at the end of every time interval or to not refresh the screen statistics.
	Click this button to refresh the status screen statistics.
Device Information	
Host Name	This is the WRE6606's system name you configure in the Maintenance > General screen.
Firmware Version	This is the firmware version and the date created.

Table 11 Status Screen: Access Point Mode (continued)

LABEL	DESCRIPTION
Sys OP Mode	This is the device mode (Section 3.1.1 on page 18) to which the WRE6606 is set - Client Mode .
LAN Information	
MAC Address	This shows the LAN Ethernet adapter MAC Address of your device.
IP Address	This shows the LAN port's IP address.
IP Subnet Mask	This shows the LAN port's subnet mask.
Default Gateway	This shows the LAN port's gateway IP address.
DHCP	This shows the LAN port's DHCP role - Client or None .
WLAN 2.4G Information	
To AP Connection	This displays whether the WRE6606 is connected to an AP or not.
To AP SSID	This displays the SSID of the connected AP. Click the Release_Configuration button to remove all configured wireless and wireless security settings for WPS connections on the WRE6606.
To AP Security	This displays the type of established security protocol with the AP.
WLAN 5G Information	
To AP Connection	This displays whether the WRE6606 is connected to an AP or not.
To AP SSID	This displays the SSID of the connected AP. Click the Release_Configuration button to remove all configured wireless and wireless security settings for WPS connections on the WRE6606.
To AP Security	This displays the type of established security protocol with the AP.
System Status	
Item	This column shows the type of data the WRE6606 is recording.
Data	This column shows the actual data recorded by the WRE6606.
System Up Time	This is the total time the WRE6606 has been on.
Current Date/Time	This field displays your WRE6606's present date and time.
System Resource	
CPU Usage	This displays what percentage of the WRE6606's processing ability is currently used. When this percentage is close to 100%, the WRE6606 is running at full load, and the throughput is not going to improve anymore. If you want some applications to have more throughput, you should turn off other applications (for example, using bandwidth management).
Memory Usage	This shows what percentage of the heap memory the WRE6606 is using.

5.4.1 Navigation Panel

Use the menu in the navigation panel to configure WRE6606 features in Client mode.

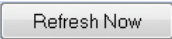
The following screen and table show the features you can configure in Client mode.

Figure 14 Menu: Client Mode



The following table describes the sub-menus.

Table 12 Navigation Panel: Access Point Mode

LINK	TAB	FUNCTION
Status	Status	This screen shows the WRE6606's general device, system and interface status information.
MONITOR		
Monitor		
Packet Statistics	Packet Statistics	Use this screen to view port status, packet specific statistics, the "system up time" and so on.
CONFIGURATION		
Network		
Wireless LAN 2.4G	AP Select	Use this screen to choose an access point that you want the WRE6606 to connect to.
Wireless LAN 5G	AP Select	Use this screen to choose an access point that you want the WRE6606 to connect to.
LAN	IP	Use this screen to configure LAN IP address and subnet mask.
OneConnect	OneConnect	Use this screen to enable or disable Wi-Fi auto-configuration.
MAINTENANCE		
General	General	Use this screen to view and change administrative settings such as system and domain names.
Password	Password Setup	Use this screen to change the password of your WRE6606.
Time	Time Setting	Use this screen to change your WRE6606's time and date.
Firmware Upgrade	Firmware Upgrade	Use this screen to upload firmware to your WRE6606.
Backup Restore	Backup Restore	Use this screen to backup and restore the configuration or reset your WRE6606 to the factory defaults.
Restart	Restart	Use this screen to reboot the WRE6606 without turning the power off.

CHAPTER 6

Repeater Mode

6.1 Overview

In repeater mode, your WRE6606 can act as an access point and wireless client at the same time. The WRE6606 can connect to an existing network through another access point and also lets wireless clients connect to the network through it. This helps you expand wireless coverage when you have an access point or wireless router already in your network.

In the example below, the WRE6606 (A) is configured as a repeater. It has three clients that want to connect to the Internet. The WRE6606 wirelessly connects to the available access point (B).

Figure 15 Repeater Mode

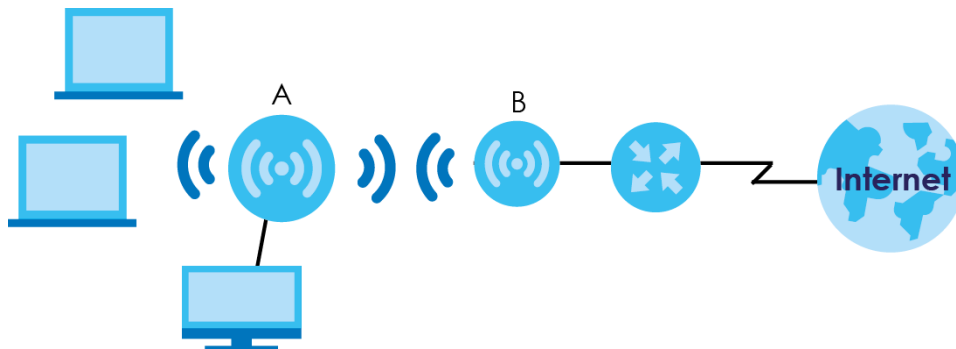

After the WRE6606 and the access point connect, the WRE6606 acquires its IP address from the access point. The clients of the WRE6606 can now surf the Internet.

6.2 What You Can Do

- Use the **Status** screen ([Section 6.4 on page 31](#)) to view read-only information about your WRE6606.
- Use the **LAN** screen ([Chapter 11 on page 78](#)) to set the IP address for your WRE6606.
- Use the **Wireless LAN > WPS** screen ([Section 10.10 on page 71](#)) to configure WPS on the WRE6606 to associate to another access point.
- Use the **Wireless LAN > AP Select** screen ([Section 10.6 on page 65](#)) to scan for available access points within transmission range and connect to an AP.
- Use other **Wireless LAN** screens ([Section 10.4 on page 58](#)) to configure the wireless settings and wireless security between the wireless clients and the WRE6606.

6.3 What You Need to Know

With the exception of the **AP Select** and **System Mode** screen, other configuration screens in Repeater mode are similar to the ones in Access Point Mode. See [Chapter 3 on page 18](#) of this User's Guide.

6.3.1 Setting your WRE6606 to Repeater Mode

- 1 To use your WRE6606 as a repeater, see [Section 3.1.1.1 on page 19](#).
- 2 Connect your computer to the LAN port of the WRE6606.
- 3 Open a web browser such as Internet Explorer and type "http://zyxelsetup" or "http://192.168.1.2" as the web address in your web browser.
- 4 Enter "1234" (default) as the password and click **Login**.
- 5 Type a new password and retype it to confirm, then click **Apply**. Otherwise, click **Ignore**.

Note: You have to log in to the Web Configurator again when you change modes. As soon as you do, your WRE6606 is already in Repeater mode.

Note: If a client is connected to the WRE6606 through the wired Ethernet connection, the client can only access the 2.4 GHz Wi-Fi. In the following figure, the LAN Client is only able to communicate with devices in the 2.4 GHz wireless network.

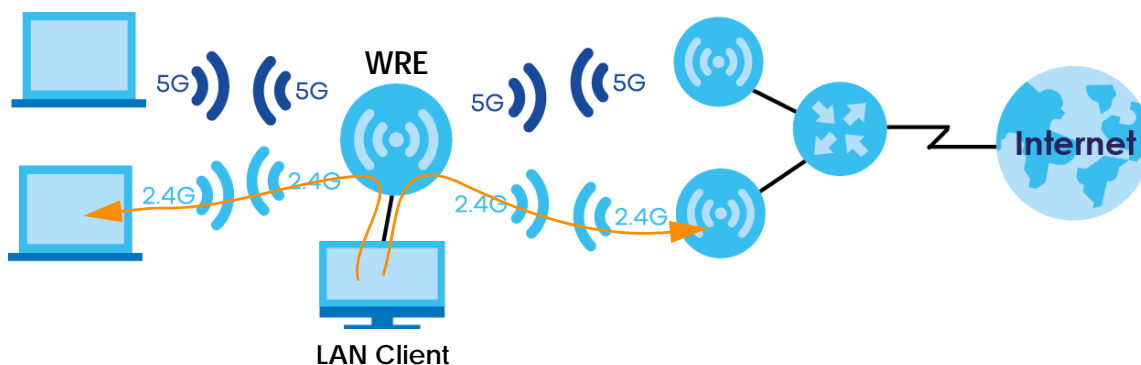

6.3.2 Configuring your WLAN, LAN and Maintenance Settings

- See [Chapter 10 on page 56](#) and [Chapter 11 on page 78](#) for information on configuring your wireless network and LAN settings.
- See [Chapter 13 on page 82](#) for information on configuring your Maintenance settings.

6.4 Repeater Mode Status Screen

Click  to open the **Status** screen.

Figure 16 Status: Repeater Mode

The following table describes the labels shown in the **Status** screen.

Table 13 Status Screen: Repeater Mode

LABEL	DESCRIPTION
	Select a number of seconds or None from the drop-down list box to refresh all screen statistics automatically at the end of every time interval or to not refresh the screen statistics.
	Click this button to refresh the status screen statistics.
Device Information	
Host Name	This is the WRE6606's system name you configure in the Maintenance > General screen.
Firmware Version	This is the firmware version and the date created.
Sys OP Mode	This is the device mode (Section 3.1.1 on page 18) to which the WRE6606 is set - Repeater Mode .
LAN Information	
MAC Address	This shows the LAN Ethernet adapter MAC Address of your device.
IP Address	This shows the LAN port's IP address.
IP Subnet Mask	This shows the LAN port's subnet mask.
Default Gateway	This shows the LAN port's gateway IP address.
DHCP	This shows the LAN port's DHCP role - Client or None .
WLAN 2.4G Information	
MAC Address	This shows the wireless adapter MAC Address of your WRE6606.

Table 13 Status Screen: Repeater Mode

LABEL	DESCRIPTION
SSID	This shows a descriptive name used to identify the WRE6606 in the wireless LAN.
Channel	This shows the channel number which you select manually or the WRE6606 automatically scans and selects.
Security	This shows the level of wireless security the WRE6606 is using.
To AP Connection	This displays whether the WRE6606 is connected to an AP or not.
To AP SSID	This displays the SSID of the connected AP. Click the Release_Configuration button to remove all configured wireless and wireless security settings for WPS connections on the WRE6606.
To AP Security	This displays the type of established security protocol with the AP.
WLAN 5G Information	
MAC Address	This shows the wireless adapter MAC Address of your WRE6606.
SSID	This shows a descriptive name used to identify the WRE6606 in the wireless LAN.
Channel	This shows the channel number which you select manually or the WRE6606 automatically scans and selects.
Security	This shows the level of wireless security the WRE6606 is using.
To AP Connection	This displays whether the WRE6606 is connected to an AP or not.
To AP SSID	This displays the SSID of the connected AP. Click the Release_Configuration button to remove all configured wireless and wireless security settings for WPS connections on the WRE6606.
To AP Security	This displays the type of established security protocol with the WRE6606.
System Status	
Item	This column shows the type of data the WRE6606 is recording.
Data	This column shows the actual data recorded by the WRE6606.
System Up Time	This is the total time the WRE6606 has been on.
Current Date/Time	This field displays your WRE6606's present date and time.
System Resource	
CPU Usage	This displays what percentage of the WRE6606's processing ability is currently used. When this percentage is close to 100%, the WRE6606 is running at full load, and the throughput is not going to improve anymore. If you want some applications to have more throughput, you should turn off other applications (for example, using bandwidth management).
Memory Usage	This shows what percentage of the heap memory the WRE6606 is using.
Interface Status	
Interface	This displays the WRE6606 port types. The port types are: LAN and WLAN .
Status	For the LAN port, this field displays Down (line is down) or Up (line is up or connected). For the WLAN, it displays Up when the WLAN is enabled or Down when the WLAN is disabled.
Rate	For the LAN ports, this displays the port speed and duplex setting or is left blank when the line is disconnected. For the WLAN, it displays the maximum transmission rate when the WLAN is enabled and is left blank when the WLAN is disabled.
Association List 2.4G	
#	This is the index number of an associated wireless station.

Table 13 Status Screen: Repeater Mode

LABEL	DESCRIPTION
MAC Address	This field displays the MAC address of an associated wireless station.
Association Time	This field displays the time a wireless station first associated with the WRE6606's WLAN network.
Association List 5G	
#	This is the index number of an associated wireless station.
MAC Address	This field displays the MAC address of an associated wireless station.
Association Time	This field displays the time a wireless station first associated with the WRE6606's WLAN network.

6.4.1 Navigation Menus

Use the menu in the navigation panel to configure WRE6606 features in Repeater mode.

The following screen and table show the features you can configure in Repeater mode.

Figure 17 Menus: Repeater Mode



The following table describes the sub-menus.

Table 14 Menus: Repeater Mode

LINK	TAB	FUNCTION
Status	Status	This screen shows the WRE6606's general device, system and interface status information.
MONITOR		
Monitor		
Packet Statistics	Packet Statistics	Use this screen to view port status, packet specific statistics, the "system up time" and so on.
CONFIGURATION		
Network		
Wireless LAN 2.4G	General	Use this screen to configure general wireless LAN and wireless security settings.
	AP Select	Use this screen to choose an access point that you want the WRE6606 to connect to.
	MAC Filter	Use this screen to configure the WRE6606 to block access to devices or block the devices from accessing the WRE6606.
	Advanced	Use this screen to configure advanced wireless settings.
	QoS	Use this screen to enable Wi-Fi MultiMedia Quality of Service (WMMQoS).
	WPS	Use this screen to enable WPS.
	WPS Device	Use this screen to add a wireless station using WPS.

Table 14 Menus: Repeater Mode

LINK	TAB	FUNCTION
Wireless LAN 5G	General	Use this screen to configure general wireless LAN settings.
	AP Select	Use this screen to choose an access point that you want the WRE6606 to connect to.
	MAC Filter	Use this screen to configure the WRE6606 to block access to devices or block the devices from accessing the WRE6606.
	Advanced	Use this screen to configure advanced wireless settings.
	QoS	Use this screen to enable Wi-Fi MultiMedia Quality of Service (WMMQoS).
	WPS	Use this screen to enable WPS.
	WPS Device	Use this screen to add a wireless station using WPS.
LAN	IP	Use this screen to configure LAN IP address and subnet mask.
OneConnect	OneConnect	Use this screen to enable or disable Wi-Fi auto-configuration.
MAINTENANCE		
General	General	Use this screen to view and change administrative settings such as system and domain names.
Password	Password Setup	Use this screen to change the password of your WRE6606.
Time	Time Setting	Use this screen to change your WRE6606's time and date.
Firmware Upgrade	Firmware Upgrade	Use this screen to upload firmware to your WRE6606.
Backup Restore	Backup Restore	Use this screen to backup and restore the configuration or reset your WRE6606 to the factory defaults.
Restart	Restart	Use this screen to reboot the WRE6606 without turning the power off.
System Mode	System Mode	Use this screen to select how you want to use your WRE6606.

CHAPTER 7

eaZy123 Wizard Setup

7.1 Overview

This chapter provides information on the wizard setup screens in the Web Configurator.

The Web Configurator's wizard setup helps you configure your device.

7.2 Use the WRE6606 as a Repeater

Follow the steps below to connect the WRE6606 to an existing AP or wireless router in your network. Note down your home wireless router or AP's current wireless network name (SSID) and password in order to connect the WRE6606 to it. Clients also use these to connect to your home wireless router or AP via the WRE6606.

- 1 Make sure that the WRE6606 switch is set to **R** (Repeater mode).
- 2 Connect your computer to the WRE6606 using an Ethernet cable.
- 3 Open your web browser and type `http://zyxelsetup` (Windows) or `http://zyxelsetup.local` (Mac). If you can't connect, check you're using a supported browser version.
- 4 The wizard runs automatically the first time you access the WRE6606. If it doesn't open, click the **eaZy123** icon on the upper right corner of any Web Configurator screen.
- 5 The wizard scans for available Wi-Fi networks and displays the network list. Select a 2.4 GHz Wi-Fi network to which you want the WRE6606 to connect to extend the network. Click **Continue**.

If the wireless router or AP you want to connect to is not listed, click **Choose Network Manually** and go to step 7 to configure the SSID and security settings manually.

If you don't want to associate with a 2.4 GHz network, click **Skip 2.4 GHz**.

ZyXEL [Skip Setup]

eaZy 123 Setup

1 Choose a 2.4 GHz Wi-Fi network

Choose your 2.4 GHz Wi-Fi network you wish to extend. We recommend to have at least 70% signal strength

Select	Signal	Wi-Fi Network	Security	Wireless
<input checked="" type="radio"/>	100%	ZyXEL_Wi-Fi	WPA2-PSK	b/g/n
<input type="radio"/>	100%	SVD_85021	WPA2-PSK	b/g/n
<input type="radio"/>	100%	EMG2926_24GGGGGGGG	WPA2-PSK	b/g/n
<input type="radio"/>	100%	REON Digital	WPA2-MIXED	b/g/n
<input type="radio"/>	100%	ZyXEL	No Security	b/g/n
<input type="radio"/>	100%	NBG4604_Kelly	WPA2-PSK	b/g/n
<input type="radio"/>	100%	ZyXELD3018C	WPA2-PSK	b/g/n

Continue Scan Again Choose Network Manually Skip 2.4 GHz

COPYRIGHT © 2016 ZYXEL COMMUNICATIONS CORP. ALL RIGHTS RESERVED

- 6 Type the selected network's Wi-Fi password (key) if wireless security is enabled. Click **Continue**.

ZyXEL [Skip Setup]

eaZy 123 Setup

2 Enter 2.4 GHz Wi-Fi Network's Password

Please enter in the 2.4 GHz wireless network's password that you're extending

Continue

COPYRIGHT © 2016 ZYXEL COMMUNICATIONS CORP. ALL RIGHTS RESERVED

- 7 If you click **Choose Network Manually**, enter the SSID and security settings of your wireless router or AP. Click **Continue**.

ZyXEL [Skip Setup]

eaZy 123 Setup

2 Manually enter in the 2.4 GHz wireless network settings

Wireless Name (SSID):

No Security ▾

Enter Wi-Fi password here

Continue

COPYRIGHT © 2016 ZYXEL COMMUNICATIONS CORP. ALL RIGHTS RESERVED

- 8 The 5 GHz setup screen displays. Repeat previous steps to select and connect to a 5 GHz Wi-Fi network.
- 9 Configure the wireless settings between the WRE6606 and its wireless clients. The WRE6606 automatically copies the SSID of the associated AP or wireless router and appends ".speed" to the 5GHz SSID. Make sure that the WRE6606's 2.4G and/or 5G Wi-Fi settings are the same as the Wi-Fi settings on your wireless router or AP. Click **Apply**.

ZyXEL [Skip Setup]

eaZy 123 Setup

3 Set Your Extender's Wireless Network

2.4 GHz Wireless Name (SSID): <input type="text" value="ZyXEL"/>	5 GHz Wireless Name (SSID): <input type="text" value="ZyXEL.speed"/>
2.4 GHz Wireless Password: <input type="text"/>	5 GHz Wireless Password: <input type="text"/>

! IMPORTANT!
 Please write down all information that you've input here, so that you can refer to it in the future. When you're ready to apply this setup, click on "Apply"



Apply

COPYRIGHT © 2016 ZYXEL COMMUNICATIONS CORP. ALL RIGHTS RESERVED

- 10 The eaZy 123 setup wizard is complete. Verify the WRE6606's wireless network settings and click **GO** if you want to log into the web configurator again.

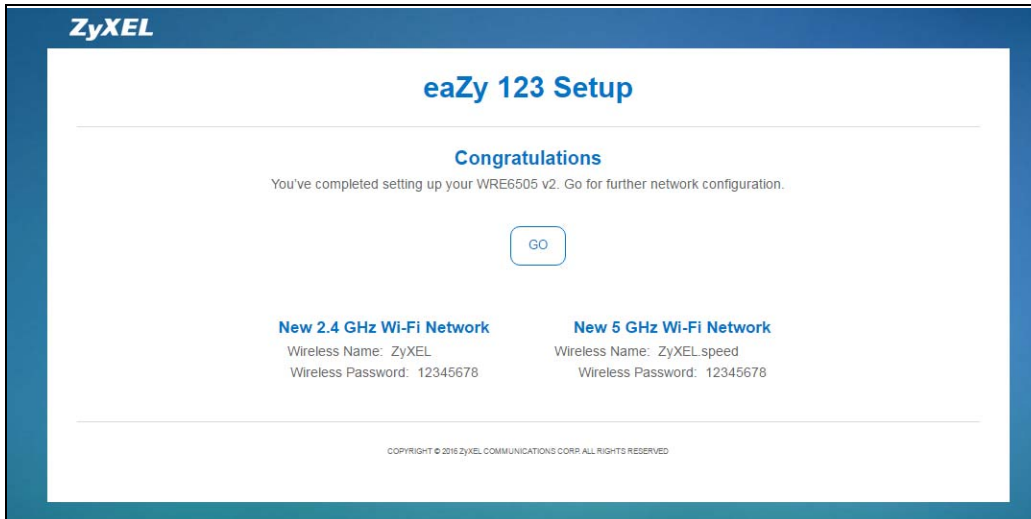

- 11 Position the WRE6606 mid-way between your wireless router or AP and the Wi-Fi dead zone where the wireless clients are.
- Disconnect the WRE6606. Connect a power bank (portable charger) with DC 5V/2.1A output to the WRE6606's micro-USB port, so that you can carry the WRE6606 around the house to determine the best deployment location. You want the WRE6606 to be close enough to the clients so that the signal is strong enough to be repeated.
 - When you have found a good location, plug the WRE6606 into a nearby outlet.
 - The 2.4G and/or 5G LEDs should be green or orange. If they're red, the WRE6606 is too far from the wireless router or AP. Move the WRE6606 closer, but not too close as to cause interference.
- 12 Remote clients can now wirelessly connect to your home wireless router or AP via the WRE6606 using the wireless router or AP's SSID and password.

7.3 Use the WRE6606 as an AP

Follow the steps below to change the Wi-Fi network name and/or Wi-Fi password that wireless clients should use to connect to the WRE6606.

- 1 Make sure that the WRE6606 switch is set to **A** (AP mode).
- 2 Connect your computer to the WRE6606 using an Ethernet cable.
- 3 Open your web browser and type <http://zyxelsetup> (Windows) or <http://zyxelsetup.local> (Mac). If you can't connect, check you're using a supported browser version.
- 4 The wizard runs automatically the first time you access the WRE6606. If it doesn't open, click the **eaZy123** icon on the upper right corner of any Web Configurator screen.
- 5 Configure the wireless settings between the WRE6606 and its wireless clients. The WRE6606 automatically copies the SSID and appends ".speed" to the 5GHz SSID. Click **Apply**.

ZyXEL

[Skip Setup]

eaZy 123 Setup

1 Check Internet

You've selected Access Point mode. Please ensure that you connect this access point to an Internet sharing device or gateway after completing this setup.

2 Wireless Network

Wireless Name (SSID):
ZyXELCC0000

Wireless Password (WPA2):
.....

Edit 5 GHz wireless network

5 GHz Wireless Name (SSID):
ZyXELCC0000.speed

5 GHz Wireless Password (WPA2):
.....

Your 5 GHz (11ac) wireless name will automatically have ".speed" added to the end. Check "Edit 5 GHz wireless network" if you would like to edit it.

3 Apply Settings

Apply

! IMPORTANT!

Please write down all information that you've input here, so that you can refer to it in the future. When you're ready to apply this setup, click on "Apply"

COPYRIGHT © 2016 ZYXEL COMMUNICATIONS CORP. ALL RIGHTS RESERVED

- 6 The eaZy 123 setup wizard is complete. Verify the WRE6606's wireless network settings and click **GO** if you want to log into the web configurator again.

ZyXEL

eaZy 123 Setup

Congratulations

You've completed setting up your WRE6505 v2. Go for further network configuration.

GO

New 2.4 GHz Wi-Fi Network

Wireless Name: ZyXEL
Wireless Password: 12345678

New 5 GHz Wi-Fi Network

Wireless Name: ZyXEL.speed
Wireless Password: 12345678

COPYRIGHT © 2016 ZYXEL COMMUNICATIONS CORP. ALL RIGHTS RESERVED

- 7 Disconnect the computer from the WRE6606 Ethernet port and connect the WRE6606 to your broadband modem or router using an Ethernet cable. Wireless clients can now connect to the Internet using the Wi-Fi network name and password you just configured in the WRE6606.

7.4 Use the WRE6606 as a Wireless Client

Follow the steps below to select and connect the WRE6606 to an existing AP or wireless router in your network.

- 1 Make sure that the WRE6606 switch is set to **C** (Client mode).
- 2 Connect your computer to the WRE6606 using an Ethernet cable.
- 3 Open your web browser and type `http://zyxelsetup` (Windows) or `http://zyxelsetup.local` (Mac). If you can't connect, check you're using a supported browser version.
- 4 The wizard runs automatically the first time you access the WRE6606. If it doesn't open, click the **eaZy123** icon on the upper right corner of any Web Configurator screen.
- 5 The wizard scans for available Wi-Fi networks and displays the network list. Select a 2.4 GHz Wi-Fi network to which you want the WRE6606 to connect to extend the network. Click **Continue**.

If the wireless router or AP you want to connect to is not listed, click **Choose Network Manually** and go to step 7 to configure the SSID and security settings manually.

If you don't want to associate with a 2.4 GHz network, click **Skip 2.4 GHz**.

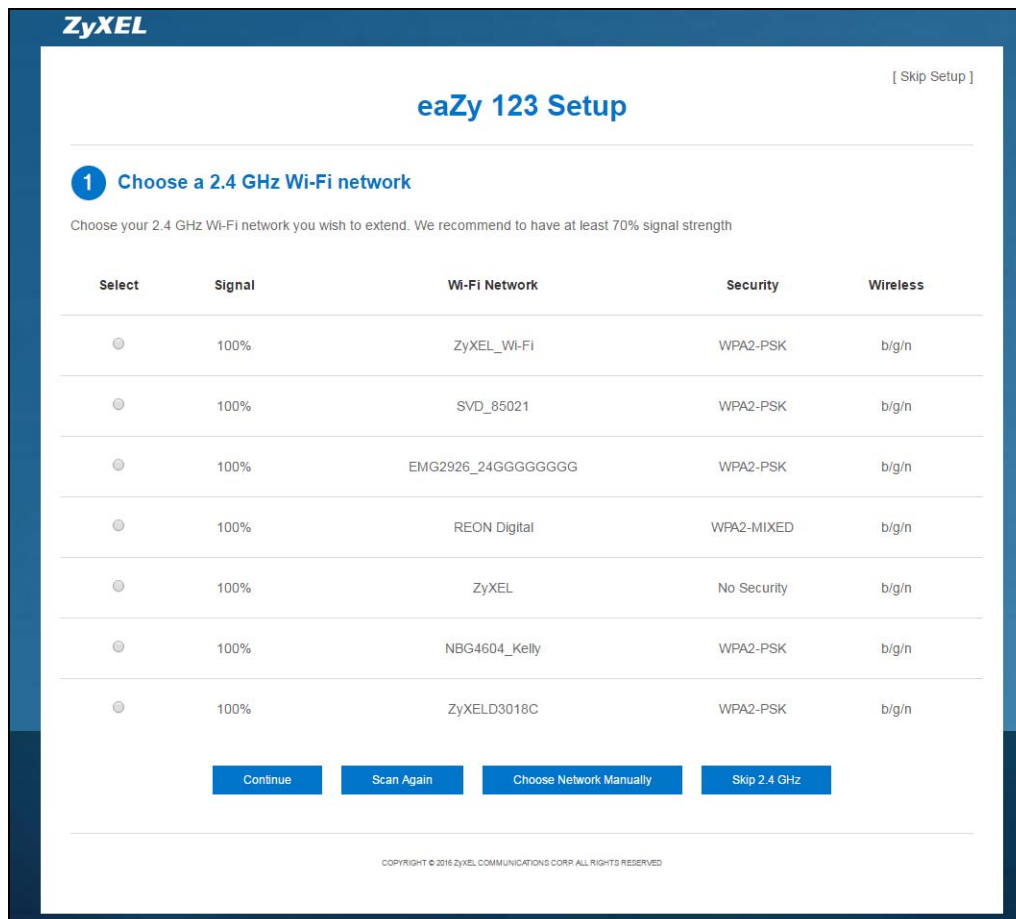

- 6 Type the selected network's Wi-Fi password (key) if wireless security is enabled. Click **Continue**.

The screenshot shows the ZyXEL eaZy 123 Setup wizard. At the top left is the ZyXEL logo. At the top right is a link that says "[Skip Setup]". The main heading is "eaZy 123 Setup". Below this is a step indicator "2" followed by the title "Enter 2.4 GHz Wi-Fi Network's Password". The instruction reads: "Please enter in the 2.4 GHz wireless network's password that you're extending". There is a text input field for the password. Below the input field is a blue "Continue" button. At the bottom of the page, there is a small copyright notice: "COPYRIGHT © 2016 ZYXEL COMMUNICATIONS CORP. ALL RIGHTS RESERVED".

- 7 If you click **Choose Network Manually**, enter the SSID and security settings of your wireless router or AP. Click **Continue**.

The screenshot shows the ZyXEL eaZy 123 Setup wizard. At the top left is the ZyXEL logo. At the top right is a link that says "[Skip Setup]". The main heading is "eaZy 123 Setup". Below this is a step indicator "2" followed by the title "Manually enter in the 2.4 GHz wireless network settings". The form contains three input fields: "Wireless Name (SSID):" with a text input field containing the placeholder "Enter Wi-Fi network here"; a security dropdown menu currently set to "No Security"; and another text input field containing the placeholder "Enter Wi-Fi password here". Below these fields is a blue "Continue" button. At the bottom of the page, there is a small copyright notice: "COPYRIGHT © 2016 ZYXEL COMMUNICATIONS CORP. ALL RIGHTS RESERVED".

- 8 The 5 GHz setup screen displays. Repeat previous steps to select and connect to a 5 GHz Wi-Fi network.
- 9 The eaZy 123 setup wizard is complete. Click **GO** if you want to log into the web configurator again.

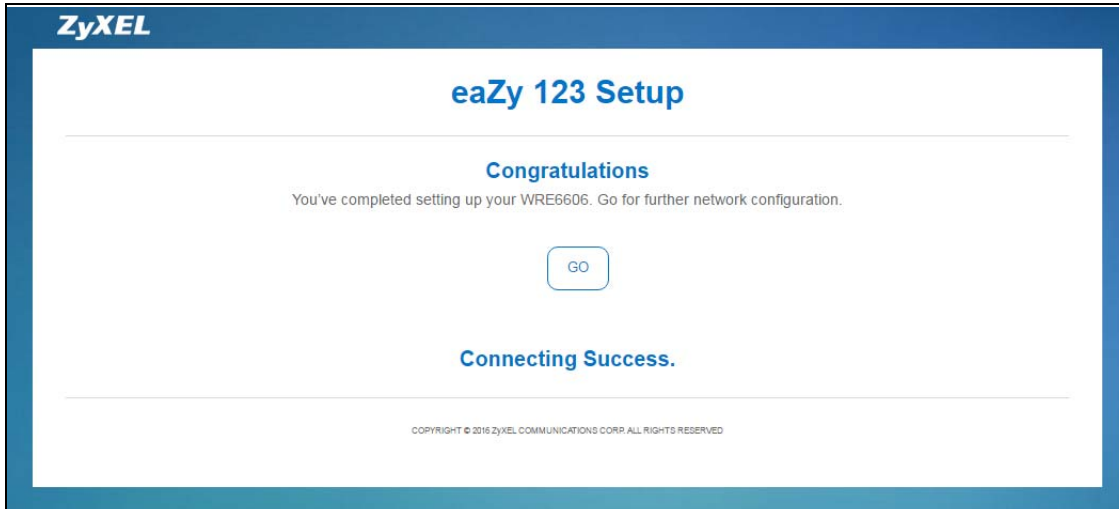

- 10 You now can use the WRE6606 as a wireless adapter and access the Internet through the wireless router by connecting your computer to the WRE6606 Ethernet port.

CHAPTER 8

Tutorials

8.1 Overview

This chapter provides tutorials for your WRE6606 as follows (in access point or repeater mode) as follows:

- [Connecting to the Internet from an Access Point](#)
- [Connecting to the WRE6606's Wireless Network Using WPS](#)
- [Connecting the WRE6606 \(in Repeater Mode\) to an AP](#)

This chapter provides tutorials for your WRE6606 (in client mode) as follows:

- [Connecting the WRE6606 \(in Client Mode\) to an AP or Wireless Router](#)

8.2 Connecting to the Internet from an Access Point

This section gives you an example of how to set up an access point (AP) and wireless client (a notebook (B), in this example) for wireless communication. B can access the Internet through the access point (A) wirelessly.

Figure 18 Wireless Access Point Connection to the Internet

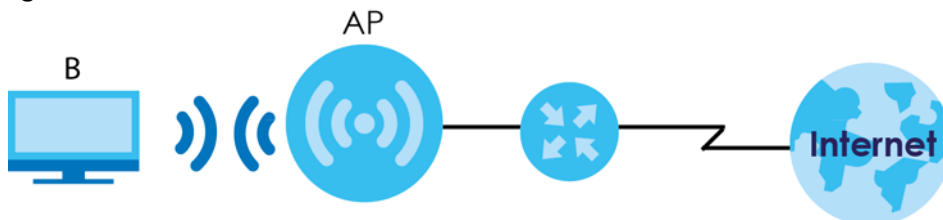

8.3 Connecting to the WRE6606's Wireless Network Using WPS

This section gives you an example of how to set up wireless networks using WPS. The following example uses the WRE6606 as the AP and a WPS-enabled Android smartphone as the wireless client.

The following WPS methods for creating a secure connection are described in the tutorial.

- **Push Button Configuration (PBC)** - create a secure wireless network simply by pressing a button. See [Section 8.3.1 on page 45](#). This is the easier method.

- **PIN Configuration** - create a secure wireless network simply by entering a wireless client's PIN (Personal Identification Number) in the WRE6606's interface. See [Section 8.3.2 on page 46](#). This is the more secure method, since one device can authenticate the other.

8.3.1 Push Button Configuration (PBC)

The push button configuration function found in the interfaces is available both in AP mode and Repeater mode. The WPS button, see [Section 1.3 on page 10](#), can also be used for PBC configurations in either AP or Repeater mode.

- 1 Make sure that your WRE6606 is turned on and set to work in AP mode and that it is within range of the wireless client.
- 2 Go to your phone settings and turn on Wi-Fi. Open the Wi-Fi networks list and tap **WPS Push Button** or the WPS icon ().
- 3 Log into WRE6606's Web Configurator. Make sure WPS is enabled in the **Network > Wireless LAN > WPS** screen.
- 4 Navigate to **Network > Wireless LAN 2.4G** or **Wireless LAN 5G > WPS Device** and press the **WPS** button.

Note: Your WRE6606 has a WPS button located on its panel, as well as a WPS button in its configuration utility. Both buttons have exactly the same function; you can use one or the other.

Note: It doesn't matter which button is pressed first. You must press the second button within two minutes of pressing the first one.

The WRE6606 sends the proper configuration settings to the wireless client. This may take up to two minutes. Then the wireless client is able to communicate with the WRE6606 securely.

The following figure shows you how to set up wireless network and security by pressing a button on both WRE6606 and wireless client (the Android smartphone in this example).

Figure 19 Example WPS Process: PBC Method

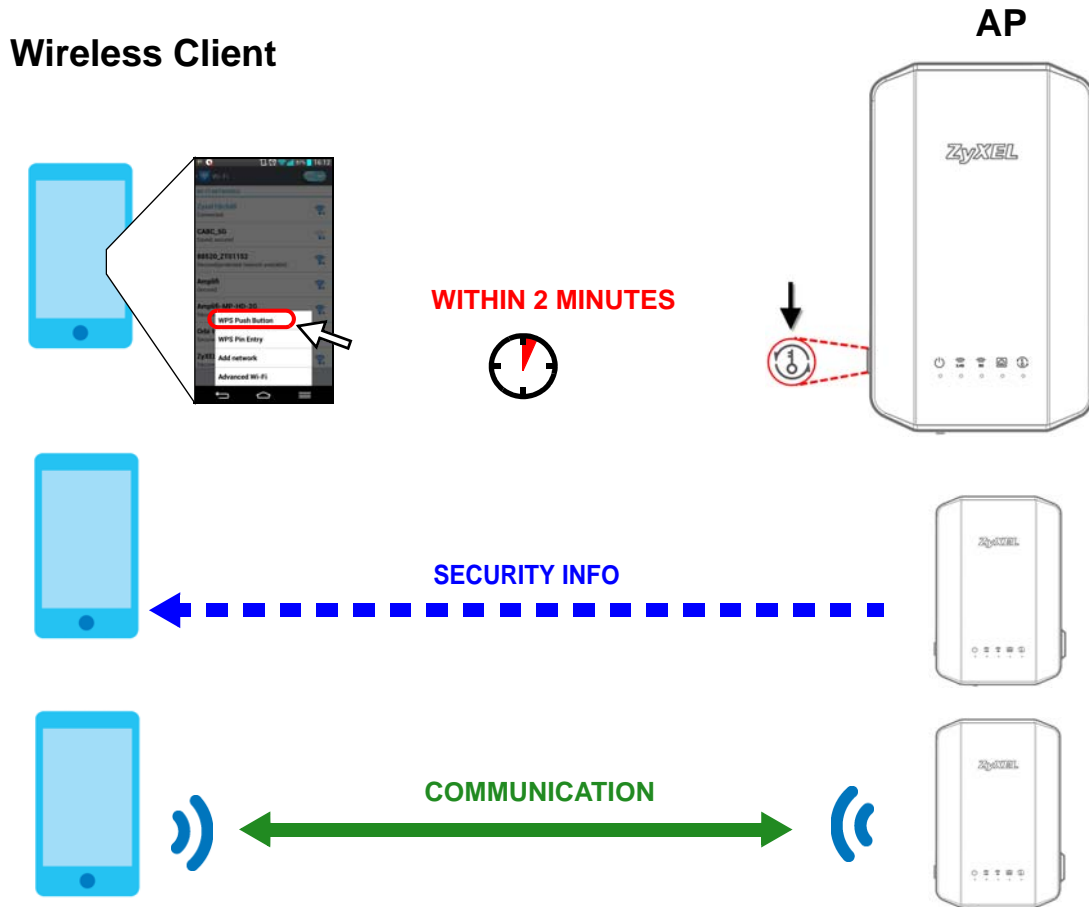

8.3.2 PIN Configuration

When you use the PIN configuration method, you need to check the client's PIN number and use the configuration interface of the WRE6606 in AP mode.

- 1 Go to your phone settings and turn on Wi-Fi. Open the Wi-Fi networks list and tap **WPS PIN Entry** to get a PIN number.
- 2 Enter the client's PIN number to the PIN field in the **Network > Wireless LAN 2.4G** or **Wireless LAN 5G > WPS Device** screen on the WRE6606 (in AP mode).
- 3 Click the **Go** button (or button next to the PIN field) on the WRE6606's **WPS Device** screen within two minutes.

The WRE6606 authenticates the wireless client and sends the proper configuration settings to the wireless client. This may take up to two minutes. Then the wireless client is able to communicate with the WRE6606 securely.

The following figure shows an example of how to set up wireless network and security on WRE6606 and wireless client (the Android smartphone in this example) by using PIN method.

Figure 20 Example WPS Process: PIN Method

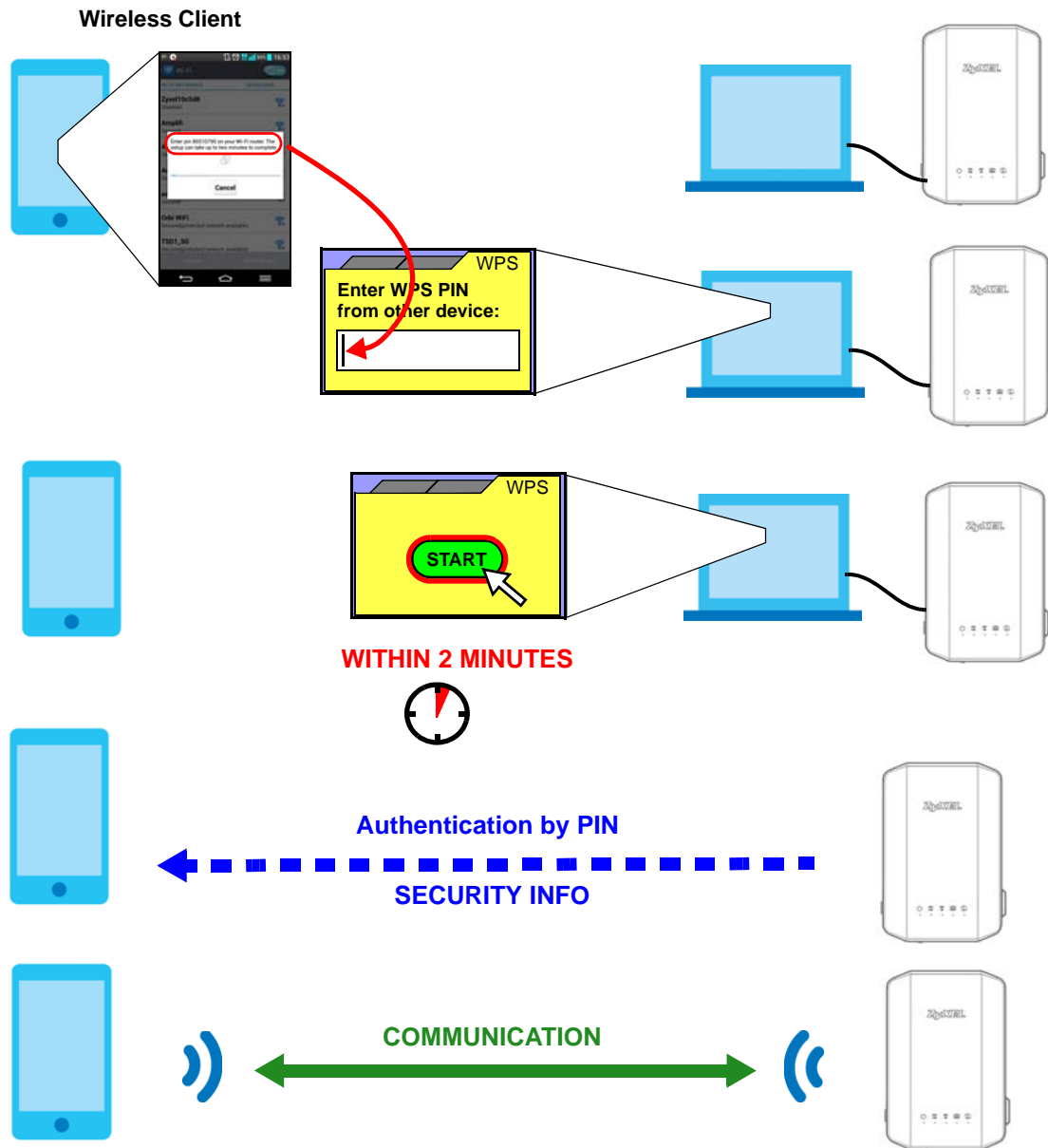

8.4 Connecting the WRE6606 (in Repeater Mode) to an AP

Repeater mode allows you to extend the original AP coverage.

- **Selecting an AP from an Automatically Detected List** - create a secure wireless network simply by selecting an AP from a list of detected APs. See [Section 8.4.1 on page 48](#). This is the easier method.
- **Selecting an AP by Manually Entering Security Information** - create a secure wireless network by manually entering the AP's wireless security settings in the WRE6606's interface. See [Section 8.4.2 on page 49](#). This is useful when the AP is hidden.

8.4.1 Selecting an AP from an Automatically Detected List

This section demonstrates the procedures in Repeater mode. Follow the steps below to create a secure wireless network by selecting an AP from a list of detected APs.

The AP select function is available both in Client mode and Repeater mode. See [Section 3.1.1 on page 18](#).

The instructions require that your hardware is connected (see the Quick Start Guide) and you are logged into the Web Configurator through your LAN connection (see [Section 2.2 on page 13](#)).

- 1 Open the **Network > Wireless LAN 2.4G** or **Wireless LAN 5G > AP Select** screen. Select an AP from the **Select** column and click **Continue**.

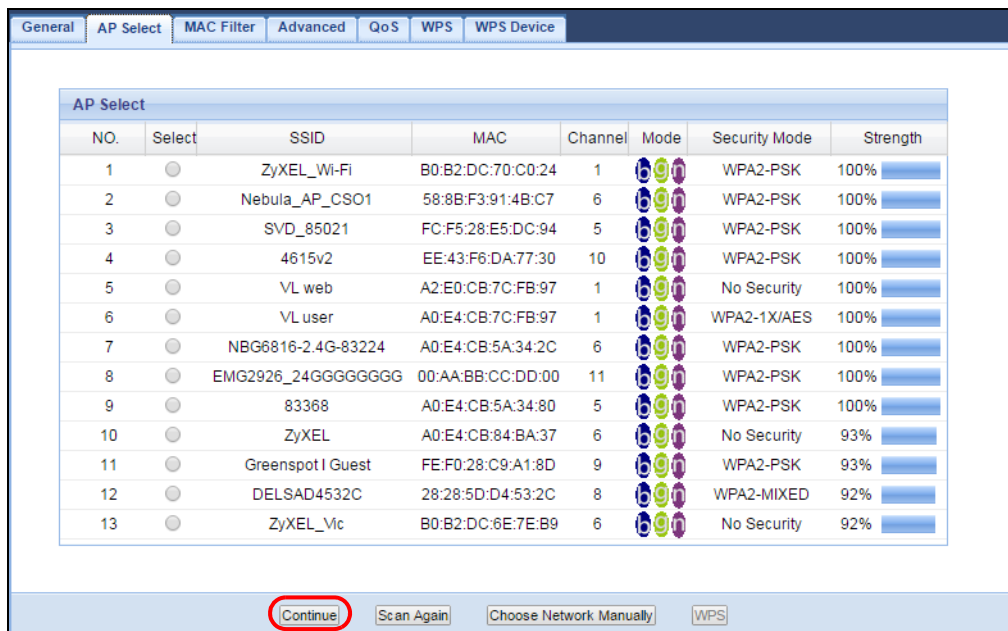

- 2 Type the Wi-Fi key if wireless security is enabled on the selected AP and click **Continue**.

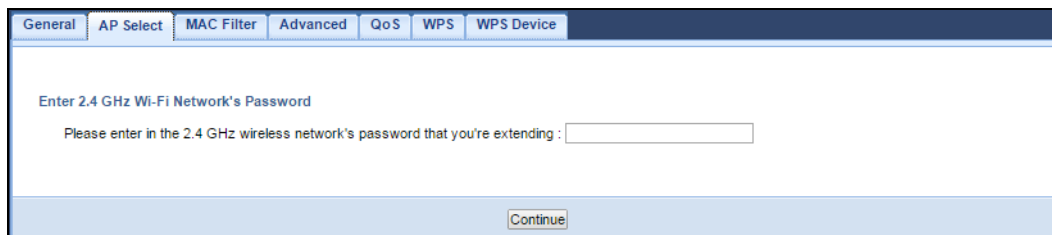

- 3 Configure the wireless settings between the WRE6606 and its wireless clients. The WRE6606 automatically copies the SSID of the associated AP and appends ".speed" to the 5GHz SSID. Click **Apply** to save settings and restart the WRE6606.

General AP Select **MAC Filter** Advanced QoS WPS WPS Device

Set Your Extender's Wireless Network

2.4 GHz Wireless Name (SSID):

2.4 GHz Wireless Password:

IMPORTANT!

Please write down all information that you've input here, so that you can refer to it in the future. When you're ready to apply this setup, click on "Apply"

- 4 You have successfully set up your WRE6606 to connect to an AP. Click **GO** to go to the **Status** screen.

General AP Select **MAC Filter** Advanced QoS WPS WPS Device

Congratulations

You've completed setting up your WRE6505 v2. Go for further network configuration.

New 5 GHz Wi-Fi Network

Wireless Name: ZyXEL.speed

Wireless Password: 1234567890

8.4.2 Selecting an AP by Manually Entering Security Information

This example shows you how to configure wireless security settings with the following parameters on your WRE6606.

SSID	ZyXEL
Security	WPA(2)-PSK
Wi-Fi Key	1234567890

Follow the steps below to create a secure wireless network by manually entering the AP's wireless security settings in the WRE6606's interface.

The instructions require that your hardware is connected (see the Quick Start Guide) and you are logged into the Web Configurator through your LAN connection (see [Section 2.2 on page 13](#)).

- 1 Open the **Network > Wireless LAN 2.4G** or **Wireless LAN 5G > AP Select** screen. Select **Choose Network Manually**.

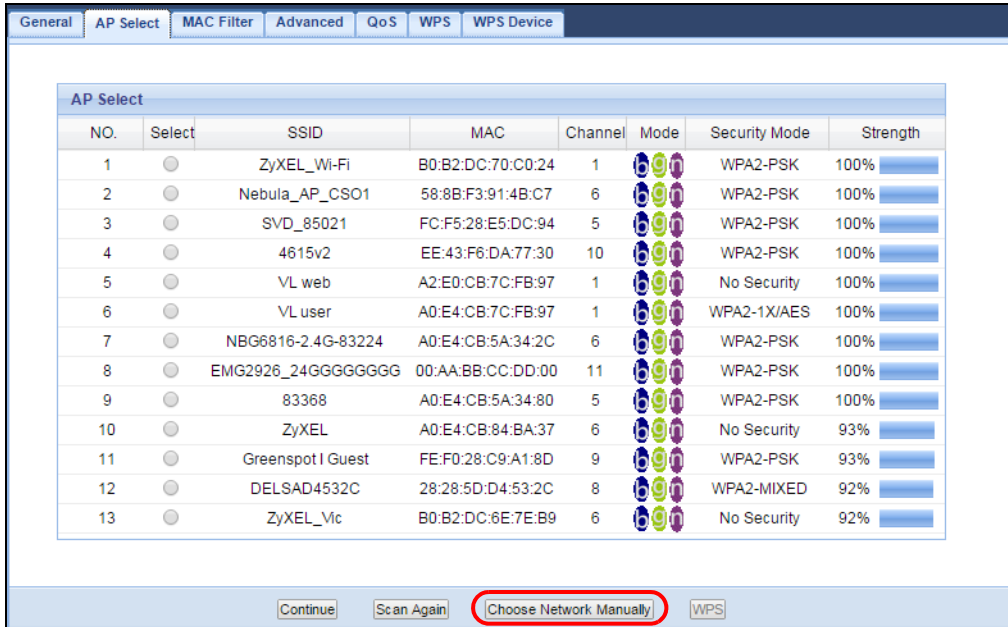

- 2 Type the SSID of the AP into the **Wireless Name (SSID)** field, set the security settings and click **Continue**.

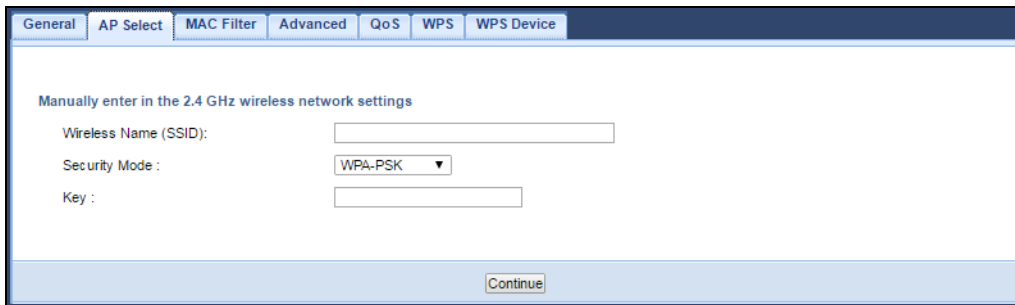

- 3 Configure the wireless settings between the WRE6606 and its wireless clients. The WRE6606 automatically copies the SSID of the associated AP and appends ".speed" to the 5GHz SSID. Click **Apply** to save settings and restart the WRE6606.

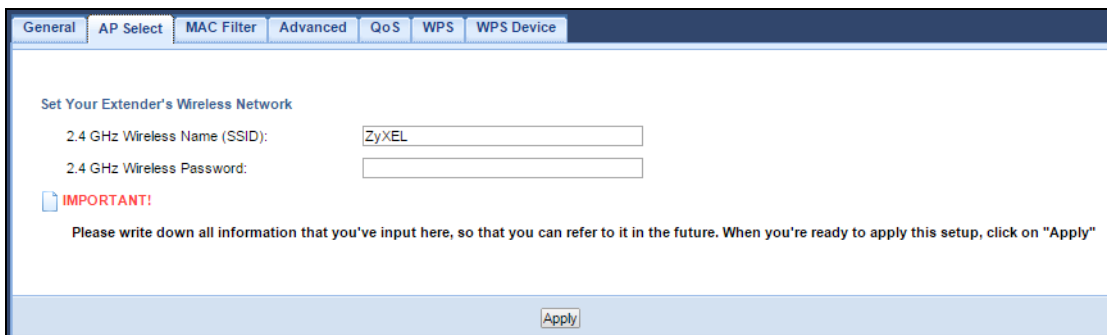

- 4 You have successfully set up your WRE6606 to connect to an AP. Click **GO** to go to the **Status** screen.

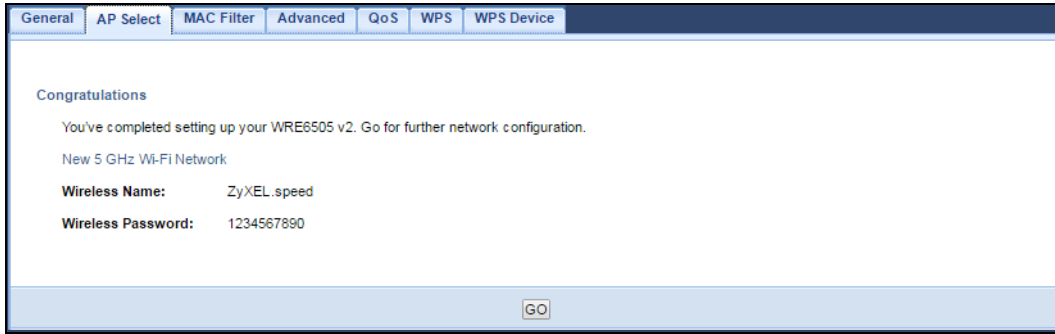

8.5 Connecting the WRE6606 (in Client Mode) to an AP or Wireless Router

If you have an access point or wireless router with Internet access deployed in your network already, and you want to use the WRE6606 as a wireless client to connect to the existing AP or wireless router, set the WRE6606 to client mode. The WRE6606 then acts as a wireless client. Your device, such as a computer, can connect to the WRE6606 through a wired connection to access the Internet.

- 1 Set your WRE6606 to work as a wireless client. See [Section 3.1.1.1 on page 19](#).
- 2 Connect your computer to the LAN port of the WRE6606 using an Ethernet cable.
- 3 Open a web browser such as Internet Explorer and type "http://zyxelsetup" (Windows) or "http://zyxelsetup.local" (Mac) as the web address in your web browser.
- 4 Enter "1234" (default) as the password and click **Login**.
- 5 Type a new password and retype it to confirm, then click **Apply**. Otherwise, click **Ignore**.
- 6 Go to **Configuration > Network > Wireless LAN 2.4G** or **Wireless LAN 5G > AP Select** screen. Select an AP from the **Select** column and click **Continue**.

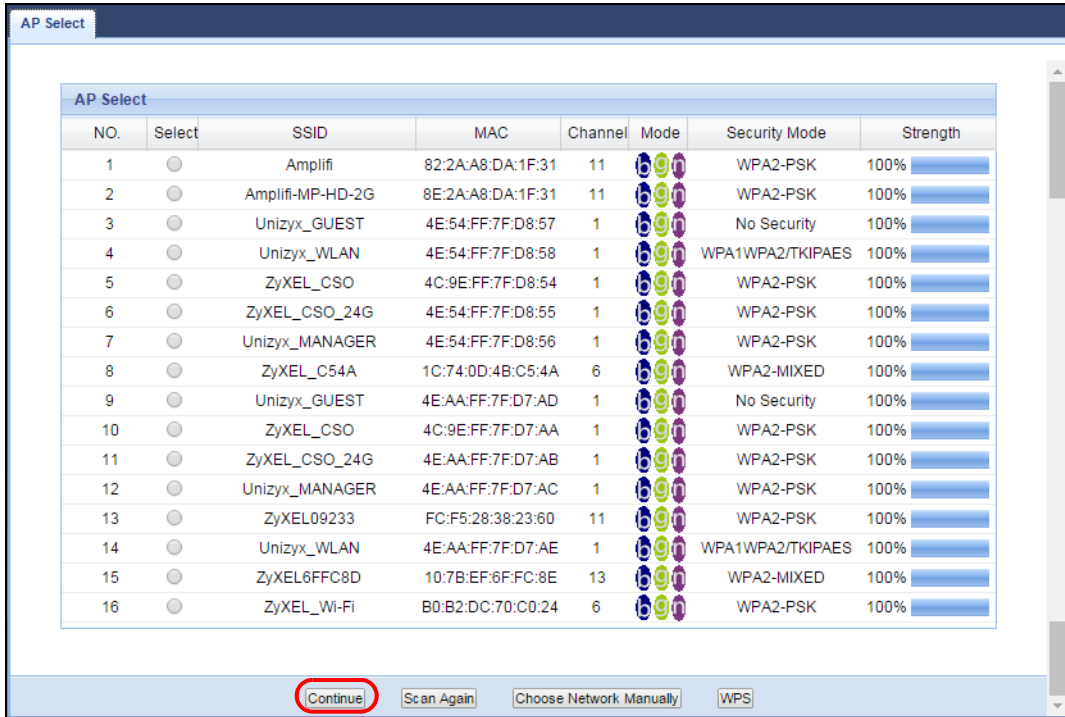

- 7 Type the Wi-Fi key if wireless security is enabled on the selected AP and click **Continue**.

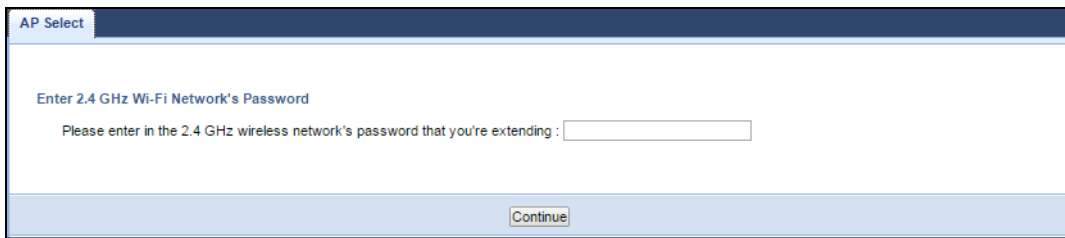

- 8 You have successfully set up your WRE6606 to connect to an AP. Click **GO** to go to the **Status** screen.

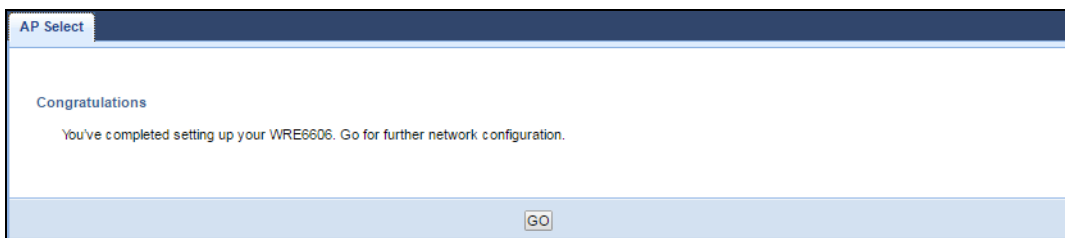

PART II

Technical Reference

CHAPTER 9

Monitor

9.1 Overview

This chapter discusses read-only information related to the device state of the WRE6606.

9.2 What You Can Do

- use the **Packet Statistics** screen ([Section 9.3 on page 54](#)) to view port status, packet specific statistics, the "system up time" and so on.

9.3 Packet Statistics Screen

Click **Monitor > Packet Statistics**. Read-only information here includes port status, packet specific statistics and the "system up time". The **Poll Interval(s)** field is configurable and is used for refreshing the screen.

Figure 21 Monitor > Packet Statistics

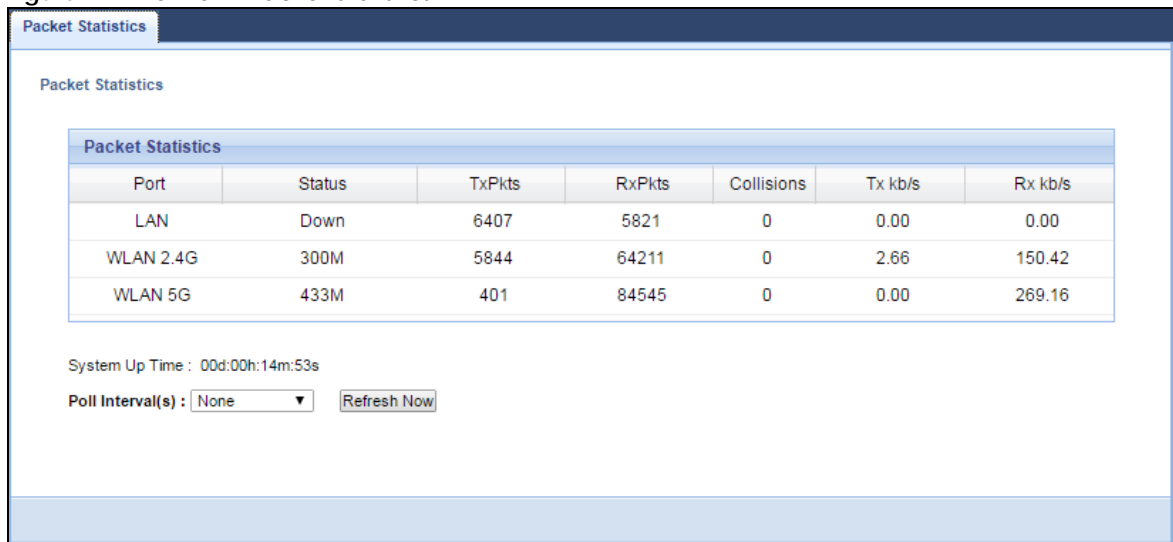

The screenshot shows the 'Packet Statistics' screen. At the top, there is a header 'Packet Statistics'. Below it, a table displays statistics for three ports: LAN, WLAN 2.4G, and WLAN 5G. The table columns are Port, Status, TxPkts, RxPkts, Collisions, Tx kb/s, and Rx kb/s. Below the table, the 'System Up Time' is shown as 00d:00h:14m:53s. At the bottom, there is a 'Poll Interval(s)' dropdown menu set to 'None' and a 'Refresh Now' button.

Port	Status	TxPkts	RxPkts	Collisions	Tx kb/s	Rx kb/s
LAN	Down	6407	5821	0	0.00	0.00
WLAN 2.4G	300M	5844	64211	0	2.66	150.42
WLAN 5G	433M	401	84545	0	0.00	269.16

System Up Time : 00d:00h:14m:53s

Poll Interval(s) :

The following table describes the labels in this screen.

Table 15 Monitor > Packet Statistics

LABEL	DESCRIPTION
Port	This is the WRE6606's port type.
Status	For the LAN ports, this displays the port speed or Down when the line is disconnected. For the WLAN, it displays the maximum transmission rate when the WLAN is enabled and Down when the WLAN is disabled.
TxPkts	This is the number of transmitted packets on this port.
RxPkts	This is the number of received packets on this port.
Collisions	This is the number of collisions on this port.
Tx kb/s	This displays the transmission speed in kilobits per second on this port.
Rx kb/s	This displays the reception speed in kilobits per second on this port.
System Up Time	This is the total time the WRE6606 has been on.
Poll Interval(s)	Select the time interval in seconds for refreshing statistics in this field.
Refresh Now	Click this button to update the screen statistics immediately.

CHAPTER 10

Wireless LAN

10.1 Overview

This chapter discusses how to configure the wireless network settings in your WRE6606. See [Section 1.1 on page 9](#) for an overview of wireless networks.

10.2 What You Can Do

- Use the **General** screen to enable the Wireless LAN (2.4G/5G), enter the SSID and select the wireless security mode ([Section 10.4 on page 58](#)).
- Use the **AP select** screen to choose an access point that you want the WRE6606 (in Client mode and Repeater mode) to connect to. You should know the security settings of the target AP ([Section 10.6 on page 65](#)).
- Use the **MAC Filter** screen to allow or deny wireless stations based on their MAC addresses from connecting to the WRE6606 ([Section 10.7 on page 69](#)).
- Use the **Advanced** screen to allow intra-BSS networking and set the RTS/CTS Threshold ([Section 10.8 on page 70](#)).
- Use the **QoS** screen to enable Wi-Fi MultiMedia Quality of Service (WMMQoS). This allows the WRE6606 to automatically set priority levels to services, such as e-mail, VoIP, chat, and so on ([Section 10.9 on page 71](#)).
- Use the **WPS** screen to enable WPS to quickly set up a wireless network with strong security, without having to configure security settings manually ([Section 10.10 on page 71](#)).
- Use the **WPS Device** screen to add a wireless station using WPS ([Section 10.11 on page 73](#)).
- Use the **Scheduling** screen to set the times your wireless LAN is turned on and off ([Section 10.12 on page 74](#)). This screen is available only when the WRE6606 is in AP mode.
- Use the **Guest WLAN** screen to configure multiple BSSs on the WRE6606 ([Section 10.13 on page 75](#)). This screen is available only when the WRE6606 is in AP mode.

10.3 What You Should Know

Every wireless network must follow these basic guidelines.

- Every wireless client in the same wireless network must use the same SSID.
The SSID is the name of the wireless network. It stands for Service Set IDentity.
- If two wireless networks overlap, they should use different channels.

Like radio stations or television channels, each wireless network uses a specific channel, or frequency, to send and receive information.

- Every wireless client in the same wireless network must use security compatible with the AP. Security stops unauthorized devices from using the wireless network. It can also protect the information that is sent in the wireless network.

10.3.1 Wireless Security Overview

The following sections introduce different types of wireless security you can set up in the wireless network.

10.3.1.1 MAC Address List

Every wireless client has a unique identification number, called a MAC address.¹ A MAC address is usually written using twelve hexadecimal characters²; for example, 00A0C5000002 or 00:A0:C5:00:00:02. To get the MAC address for each wireless client, see the appropriate User's Guide or other documentation.

You can use the MAC Address List to tell the AP which wireless clients are allowed to use the wireless network. If a wireless client is allowed to use the wireless network, it still has to have the correct settings (SSID, channel, and security). If a wireless client is not allowed to use the wireless network, it does not matter if it has the correct settings.

This type of security does not protect the information that is sent in the wireless network. Furthermore, there are ways for unauthorized devices to get the MAC address of an authorized wireless client. Then, they can use that MAC address to use the wireless network.

10.3.1.2 Encryption

Wireless networks can use encryption to protect the information that is sent in the wireless network. Encryption is like a secret code. If you do not know the secret code, you cannot understand the message.

Table 16 Types of Encryption for Each Type of Authentication

NO AUTHENTICATION	
Weakest  Strongest	No Security
	Static WEP
	WPA-PSK
	WPA2-PSK

For example, if users do not log in to the wireless network, you can choose no authentication, if users do log on to the wireless network, you can choose **No Security**, **Static WEP**, **WPA-PSK**, or **WPA2-PSK**.

Usually, you should set up the strongest encryption that every wireless client in the wireless network supports. Suppose the wireless network has two wireless clients. Device A only supports WEP, and device B supports WEP and WPA-PSK. Therefore, you should set up **Static WEP** in the wireless network.

Note: It is recommended that wireless networks use WPA-PSK, or stronger encryption. IEEE 802.1x and WEP encryption are better than none at all, but it is still possible for unauthorized devices to figure out the original information pretty quickly.

1. Some wireless devices, such as scanners, can detect wireless networks but cannot use wireless networks. These kinds of wireless devices might not have MAC addresses.
2. Hexadecimal characters are 0, 1, 2, 3, 4, 5, 6, 7, 8, 9, A, B, C, D, E, and F.

Many types of encryption use a key to protect the information in the wireless network. The longer the key, the stronger the encryption. Every wireless client in the wireless network must have the same key.

10.3.1.3 WPS

Wi-Fi Protected Setup (WPS) is an industry standard specification, defined by the Wi-Fi Alliance. WPS allows you to quickly set up a wireless network with strong security, without having to configure security settings manually. Depending on the devices in your network, you can either press a button (on the device itself, or in its configuration utility) or enter a PIN (Personal Identification Number) in the devices. Then, they connect and set up a secure network by themselves. See how to set up a secure wireless network using WPS in the [Section 8.3 on page 44](#).

10.3.2 Guest WLAN

Guest WLAN allows you to set up a wireless network where users can access the Internet via the WRE6606 (**Z**), but not other networks connected to the **Z**. In the following figure, a guest user can access the Internet from the guest wireless network **A** via **Z** but not the home or company network **N**.

Note: Note: The home or company network **N** and Guest WLAN network are independent networks.

Note: Note: Only AP mode supports Guest WLAN.

Figure 22 Guest Wireless LAN Network

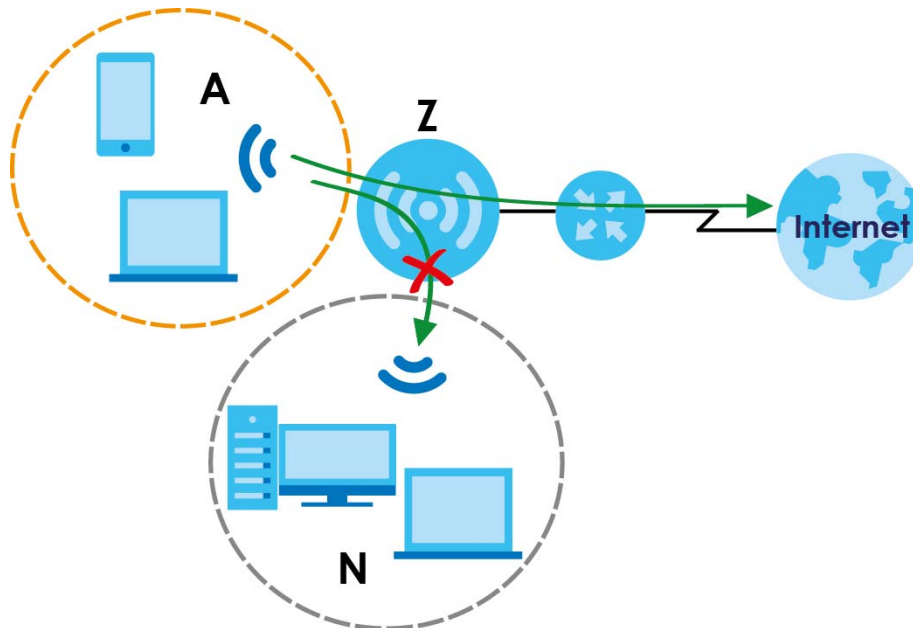

10.4 General Wireless LAN Screen

Use this screen to enable the Wireless LAN, enter the SSID and select the wireless security mode.

Note: If you are configuring the WRE6606 from a computer connected to the wireless LAN and you change the WRE6606's SSID, channel or security settings, you will lose your wireless connection when you press **Apply** to confirm. You must then change the wireless settings of your computer to match the WRE6606's new settings.

Click **Network > Wireless LAN 2.4G** or **Wireless LAN 5G** to open the **General** screen.

Figure 23 Network > Wireless LAN 2.4G/5G > General (Repeater Mode)

General | AP Select | MAC Filter | Advanced | QoS | WPS | WPS Device

Wireless Setup

Wireless LAN : Enable Disable

Network Name(SSID) :

Hide SSID

Operating Channel : Channel-11 2462MHz

Network Mode :

Channel Bandwidth : 20 40 20/40

Security

Security Mode :

WPA Compatible

Pre-Shared Key :

Group Key Update Timer : seconds

Note: No Security and WPA2-PSK can be configured when WPS enabled

Figure 24 Network > Wireless LAN 2.4G/5G > General (AP Mode)

General | MAC Filter | Advanced | QoS | WPS | WPS Device | Scheduling | Guest WLAN

Wireless Setup

Wireless LAN : Enable Disable

Network Name(SSID) :

Hide SSID

Channel Selection : Auto Channel Selection

Operating Channel : Channel-05 2432MHz

Network Mode :

Channel Bandwidth : 20 40 20/40

Security

Security Mode :

WPA Compatible

Pre-Shared Key :

Group Key Update Timer : seconds

Note: No Security and WPA2-PSK can be configured when WPS enabled

The following table describes the general wireless LAN labels in this screen.

Table 17 Network > Wireless LAN 2.4G/5G > General

LABEL	DESCRIPTION
Wireless Setup	
Wireless LAN	This is turned on by default. Click Disable to turn off the wireless LAN function.
Network Name (SSID)	The SSID (Service Set IDentity) identifies the Service Set with which a wireless client is associated. Enter a descriptive name (up to 32 printable characters found on a typical English language keyboard) for the wireless LAN.
Hide SSID	Select this check box to hide the SSID in the outgoing beacon frame so a wireless client cannot obtain the SSID through scanning using a site survey tool.
Channel Selection	<p>Set the operating frequency/channel depending on your particular region.</p> <p>Select a channel from the drop-down list box. The options vary depending on the frequency band and the country you are in.</p> <p>This option is only available when the WRE6606 is in AP mode and Auto Channel Selection is disabled.</p>
Auto Channel Selection	<p>This option is available only when the WRE6606 is in AP mode.</p> <p>Select this option to have the WRE6606 automatically scan for and select a channel which is not used by another device.</p>
Operating Channel	This displays the channel the WRE6606 is currently using.
Network Mode	<p>2.4 GHz is the frequency used by IEEE 802.11b/g/n wireless clients.</p> <p>5 GHz is the frequency used by IEEE 802.11ac/a/n wireless clients.</p> <p>Select 2.4 GHz (802.11b) to allow only IEEE 802.11b compliant WLAN devices to associate with the WRE6606.</p> <p>Select 2.4 GHz (802.11g) to allow only IEEE 802.11g compliant WLAN devices to associate with the WRE6606.</p> <p>Select 2.4 GHz (802.11n) to allow only IEEE 802.11n compliant WLAN devices to associate with the WRE6606.</p> <p>Select 2.4 GHz (802.11b/g) to allow both IEEE802.11b and IEEE802.11g compliant WLAN devices to associate with the WRE6606. The transmission rate of your WRE6606 might be reduced.</p> <p>Select 2.4 GHz (802.11b/g/n) to allow both IEEE802.11b, IEEE802.11g and IEEE802.11n compliant WLAN devices to associate with the WRE6606. The transmission rate of your WRE6606 might be reduced.</p> <p>Select 5 GHz (802.11a) to allow only IEEE 802.11a compliant WLAN devices to associate with the WRE6606.</p> <p>Select 5 GHz (802.11a/n) to allow both IEEE802.11a and IEEE802.11n compliant WLAN devices to associate with the WRE6606. The transmission rate of your WRE6606 might be reduced.</p> <p>Select 5 GHz (802.11a/n/ac) to allow both IEEE802.11a, IEEE802.11n and IEEE802.11ac compliant WLAN devices to associate with the WRE6606. The transmission rate of your WRE6606 might be reduced.</p>

Table 17 Network > Wireless LAN 2.4G/5G > General (continued)

LABEL	DESCRIPTION
Channel Bandwidth	<p>Select the channel bandwidth you want to use for your wireless network.</p> <p>Select 20 MHz if you want to lessen radio interference with other wireless devices in your neighborhood.</p> <p>Select 40 MHz if you want to lessen radio interference with other wireless devices in your neighborhood.</p> <p>Select 20/40 MHz to allow the WRE6606 to choose the channel bandwidth (20 or 40 MHz) that has least interference.</p> <p>Select 20/40/80 MHz to allow the WRE6606 to choose the channel bandwidth (20 or 40 or 80 MHz) that has least interference. This option is available only when you select 5 GHz (802.11a/n/ac) in the Network Mode field.</p>
Security	
Security Mode	<p>If the WRE6606 is in repeater mode, select No Security or the available modes to match as provided by the source AP or wireless router.</p> <p>If the WRE6606 is in AP mode, select WPA2-PSK, WPA-PSK or Static WEP to add security on this wireless network. The wireless clients which want to associate to this network must have same wireless security settings as this device. After you select to use a security, additional options appears in this screen. See Section 10.5 on page 61 for detailed information on different security modes. Or you can select No Security to allow any client to associate this network without authentication.</p> <p>Note: If the WPS function is enabled (default), only No Security and WPA2-PSK are available in this field.</p>
WPA Compatible	<p>This field appears when you choose WPA2-PSK as the Security Mode.</p> <p>Check this field to allow wireless devices using WPA-PSK security mode to connect to your WRE6606.</p>
Pre-Shared Key	<p>WPA-PSK/WPA2-PSK uses a simple common password for authentication.</p> <p>Type a pre-shared key from 8 to 63 case-sensitive keyboard characters.</p>
Group Key Update Timer	<p>The Group Key Update Timer is the rate at which the AP sends a new group key out to all clients.</p> <p>The default is 3600 seconds (60 minutes).</p>
Apply	Click Apply to save your changes back to the WRE6606.
Reset	Click Reset to return to the previous menu without saving.

10.5 Wireless Security

The screen varies depending on what you select in the **Security Mode** field.

10.5.1 No Security

Select **No Security** to allow wireless clients to communicate with the access point without any data encryption.

Note: If you do not enable any wireless security on your WRE6606, your network is accessible to any wireless networking device that is within range.

Figure 25 Network > Wireless LAN 2.4G/5G > General: No Security

The screenshot shows a configuration page with the following settings:

- Wireless Setup:**
 - Wireless LAN: Enable Disable
 - Network Name(SSID): ZyXELE24502
 - Hide SSID:
 - Channel Selection: Channel-11 2462MHz (dropdown), Auto Channel Selection
 - Operating Channel: Channel-05 2432MHz
 - Network Mode: 2.4 GHz (802.11b/g/n) (dropdown)
 - Channel Bandwidth: 20 40 20/40
- Security:**
 - Security Mode: No Security (dropdown)

Note: No Security and WPA2-PSK can be configured when WPS enabled

Buttons: Apply, Reset

The following table describes the labels in this screen.

Table 18 Network > Wireless LAN 2.4G/5G > General: No Security

LABEL	DESCRIPTION
Security Mode	Choose No Security from the drop-down list box.
Apply	Click Apply to save your changes back to the WRE6606.
Reset	Click Reset to reload the previous configuration for this screen.

10.5.2 WEP Encryption

WEP encryption scrambles the data transmitted between the wireless stations and the access points to keep network communications private. It encrypts unicast and multicast communications in a network. Both the wireless stations and the access points must use the same WEP key.

Your WRE6606 allows you to configure up to four 64-bit or 128-bit WEP keys but only one key can be enabled at any one time.

Select **Static WEP** from the **Security Mode** list.

Figure 26 Network > Wireless LAN 2.4G/5G > General: Static WEP

The following table describes the wireless LAN security labels in this screen.

Table 19 Network > Wireless LAN 2.4G/5G > General: Static WEP

LABEL	DESCRIPTION
Security Mode	Select Static WEP to enable data encryption.
PassPhrase	Enter a Passphrase (up to 26 printable characters) and click Generate . A passphrase functions like a password. In WEP security mode, it is further converted by the WRE6606 into a complicated string that is referred to as the "key". This key is requested from all devices wishing to connect to a wireless network.
WEP Encryption	Select 64-bits or 128-bits . This dictates the length of the security key that the network is going to use.
Authentication Method	Select Auto or Shared Key from the drop-down list box. This field specifies whether the wireless clients have to provide the WEP key to login to the wireless client. Keep this setting at Auto unless you want to force a key verification before communication between the wireless client and the WRE6606 occurs. Select Shared Key to force the clients to provide the WEP key prior to communication.
ASCII	Select this option in order to enter ASCII characters as WEP key.

Table 19 Network > Wireless LAN 2.4G/5G > General: Static WEP (continued)

LABEL	DESCRIPTION
Hex	Select this option in order to enter hexadecimal characters as a WEP key. The preceding "0x", that identifies a hexadecimal key, is entered automatically.
Key 1 to Key 4	The WEP keys are used to encrypt data. Both the WRE6606 and the wireless stations must use the same WEP key for data transmission. If you chose 64-bits , then enter any 5 ASCII characters or 10 hexadecimal characters ("0-9", "A-F"). If you chose 128-bits , then enter 13 ASCII characters or 26 hexadecimal characters ("0-9", "A-F"). You must configure at least one key, only one key can be activated at any one time. The default key is key 1.
Apply	Click Apply to save your changes back to the WRE6606.
Reset	Click Reset to reload the previous configuration for this screen.

10.5.3 WPA-PSK/WPA2-PSK

Select **WPA-PSK** or **WPA2-PSK** from the **Security Mode** list.

Figure 27 Network > Wireless LAN 2.4G/5G > General: WPA-PSK/WPA2-PSK

The screenshot shows the configuration page for WPA-PSK/WPA2-PSK. The tabs at the top are General, MAC Filter, Advanced, QoS, WPS, WPS Device, Scheduling, and Guest WLAN. The 'Wireless Setup' section includes: Wireless LAN (radio buttons for Enable and Disable, with Enable selected), Network Name (SSID) (text box with 'ZyXELE24502'), Hide SSID (checkbox), Channel Selection (dropdown menu with 'Channel-11 2462MHz' and 'Auto Channel Selection' checked), Operating Channel (text box with 'Channel-05 2432MHz'), Network Mode (dropdown menu with '2.4 GHz (802.11b/g/n)'), and Channel Bandwidth (radio buttons for 20, 40, and 20/40, with 20/40 selected). The 'Security' section includes: Security Mode (dropdown menu with 'WPA2-PSK'), WPA Compatible (checkbox), Pre-Shared Key (text box with '767179C7A2BFF'), and Group Key Update Timer (text box with '3600' and 'seconds'). A note at the bottom states: 'Note: No Security and WPA2-PSK can be configured when WPS enabled'. At the bottom right are 'Apply' and 'Reset' buttons.

The following table describes the labels in this screen.

Table 20 Network > Wireless LAN 2.4G/5G > General: WPA-PSK/WPA2-PSK

LABEL	DESCRIPTION
Security Mode	Select WPA-PSK or WPA2-PSK to enable data encryption.
WPA Compatible	This field appears when you choose WPA2-PSK as the Security Mode . Check this field to allow wireless devices using WPA-PSK security mode to connect to your WRE6606.

Table 20 Network > Wireless LAN 2.4G/5G > General: WPA-PSK/WPA2-PSK (continued)

LABEL	DESCRIPTION
Pre-Shared Key	WPA-PSK/WPA2-PSK uses a simple common password for authentication. Type a pre-shared key from 8 to 63 case-sensitive keyboard characters.
Group Key Update Timer	The Group Key Update Timer is the rate at which the AP sends a new group key out to all clients. The default is 3600 seconds (60 minutes).
Apply	Click Apply to save your changes back to the WRE6606.
Reset	Click Reset to reload the previous configuration for this screen.

10.6 AP Select Screen

Use this screen (available both in Client mode and Repeater mode.) to choose an access point that you want the WRE6606 to connect to. You should know the security settings of the target AP.

To open this screen, click **Network > Wireless LAN 2.4G** or **Wireless LAN 5G > AP Select**.

Figure 28 Network > Wireless LAN 2.4G/5G > AP Select (Repeater Mode)

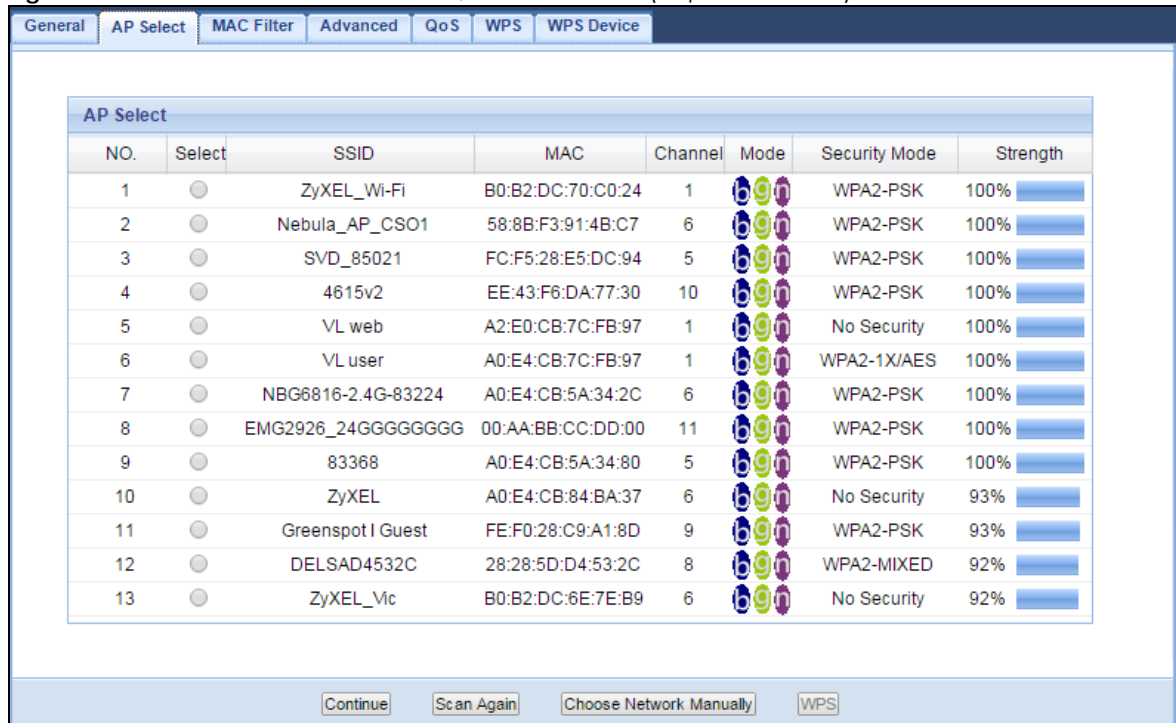

Figure 29 Network > Wireless LAN 2.4G/5G > AP Select (Client Mode)

NO.	Select	SSID	MAC	Channel	Mode	Security Mode	Strength
1	<input type="radio"/>	83368_6817	1C:74:0D:10:00:0C	3	bgn	WPA2-PSK	98%
2	<input type="radio"/>	EMG3425-24G	E8:37:7A:86:6F:40	10	bgn	WPA2-PSK	97%
3	<input type="radio"/>	ZyXEL_CSO_24G	B2:80:DC:6A:9F:05	1	bgn	WPA2-PSK	96%
4	<input type="radio"/>	Nebula_AP_SSID1	58:8B:F3:91:4B:CA	1	bgn	WPA2-PSK	96%
5	<input type="radio"/>	ZyXEL_CSO	50:67:F0:37:FD:6C	1	bgn	WPA2-PSK	95%
6	<input type="radio"/>	ZyXEL	90:EF:68:FA:EC:73	11	bgn	WPA2-PSK	93%
7	<input type="radio"/>	ZyXEL_Wi-Fi	B0:B2:DC:70:C0:24	1	bgn	WPA2-PSK	92%
8	<input type="radio"/>	ZyXEL_CSO_24G	52:60:F0:37:FD:6C	1	bgn	WPA2-PSK	92%
9	<input type="radio"/>	ZyXEL_UXD	FC:F5:28:D3:45:FC	6	bgn	WPA2-MIXED	91%
10	<input type="radio"/>	Aumento Guest	FE:F0:28:C9:A1:93	1	bgn	WPA2-PSK	90%
11	<input type="radio"/>	0ZyxelDo	E8:37:7A:86:75:68	10	bgn	WPA2-PSK	90%
12	<input type="radio"/>	test_HT	5A:8B:84:49:96:C0	10	bgn	WPA2-PSK	90%
13	<input type="radio"/>	WeiWeiWeiWeiWei	90:EF:68:C1:26:2E	1	bgn	WPA2-PSK	87%

Buttons at the bottom: Continue, Scan Again, Choose Network Manually, WPS

The following table describes the labels in this screen.

Table 21 Network > Wireless LAN 2.4G/5G > AP Select (Client Mode and Repeater Mode)

LABEL	DESCRIPTION
Select	Use the radio button to select the wireless device to which you want to connect.
SSID	This displays the Service Set IDentity of the wireless device. The SSID is a unique name that identifies a wireless network. All devices in a wireless network must use the same SSID.
MAC	This displays the MAC address of the wireless device.
Channel	This displays the channel number used by this wireless device.
Mode	This displays which IEEE 802.11b/g/n wireless networking standards the wireless device supports.
Security Mode	This displays the type of security configured on the wireless device. When No Security is shown, no security is configured and you can connect to it without a password.
Strength	This displays the strength of the wireless signal. The signal strength mainly depends on the antenna output power and the distance between your WRE6606 and this device.
Continue	Click Continue to start the next step in the AP setup process.
Scan Again	Click Scan Again to search for available wireless devices within transmission range and update this table.
Choose Network Manually	Select this to set up the AP manually.
WPS	This button is configurable only when you enable WPS in the Wireless LAN 2.4G/5G > WPS screen. Click this button to connect to the selected AP via WPS.

Enter a Wi-Fi key

If wireless security is enabled on the selected AP, the following screen displays after you click **Continue** in the **AP Select** screen. Enter the AP's Wi-Fi key and click **Continue**.

Figure 30 Network > Wireless LAN 2.4G/5G > AP Select (Repeater Mode)

Figure 31 Network > Wireless LAN 2.4G/5G > AP Select (Client Mode)

Set up the WRE6606's WLAN for clients

The following screen is available in Repeater mode only. Use this screen to configure the wireless settings between the WRE6606 and its wireless clients. The WRE6606 automatically copies the SSID of the associated AP. You can set the SSID and Wi-Fi key of the WRE6606's WLAN to be the same as those on the AP to which the WRE6606 wants to connect. Click **Apply** to save your settings.

Figure 32 Network > Wireless LAN 2.4G/5G > AP Select (Repeater Mode)

Choose AP network manually

Use this screen to manually enter the SSID, security mode and Wi-Fi key of the AP to which you want the WRE6606 to connect. This is useful when the AP's SSID is hidden. Click **Continue** to configure the wireless settings between the WRE6606 and its wireless clients (see [Set up the WRE6606's WLAN for clients on page 67](#)).

Figure 33 Network > Wireless LAN 2.4G/5G > AP Select (Repeater Mode)

General AP Select MAC Filter Advanced QoS WPS WPS Device

Manually enter in the 2.4 GHz wireless network settings

Wireless Name (SSID):

Security Mode:

Key:

Continue

Figure 34 Network > Wireless LAN 2.4G/5G > AP Select (Client Mode)

AP Select

Manually enter in the 2.4 GHz wireless network settings

Wireless Name (SSID):

Security Mode:

Key:

Continue

Complete the AP and WLAN setup

This screen displays when you have successfully set up your WRE6606 to connect to an AP. Verify the WRE6606's wireless network settings and click **GO** to open the **Status** screen.

Figure 35 Network > Wireless LAN 2.4G/5G > AP Select (Repeater Mode)

General AP Select MAC Filter Advanced QoS WPS WPS Device

Congratulations

You've completed setting up your WRE6505 v2. Go for further network configuration.

New 5 GHz Wi-Fi Network

Wireless Name: ZyXEL.speed

Wireless Password: 1234567890

GO

Figure 36 Network > Wireless LAN 2.4G/5G > AP Select (Client Mode)

AP Select

Congratulations

You've completed setting up your WRE6606. Go for further network configuration.

GO

10.7 MAC Filter

The MAC Filter screen allows you to specify which devices are allowed to access the WRE6606, while denying access to all unspecified devices. Every Ethernet device has a unique MAC (Media Access Control) address. The MAC address is assigned at the factory and consists of six pairs of hexadecimal characters, for example, 00:A0:C5:00:00:02. You need to know the MAC address of the devices to configure this screen.

To change your WRE6606's MAC Address List settings, click **Network > Wireless LAN 2.4G** or **Wireless LAN 5G > MAC Filter**. The screen appears as shown.

Figure 37 Network > Wireless LAN 2.4G/5G > MAC Filter

The following table describes the labels in this menu.

Table 22 Network > Wireless LAN 2.4G/5G> MAC Filter

LABEL	DESCRIPTION
SSID for MAC Filter	Select the SSID for which you want to configure MAC filtering.
Policy	Define the filter action for the list of MAC addresses in the MAC Address table. Select Disable to deactivate the MAC filtering rule you configure below. Select Allow to permit access to the WRE6606, MAC addresses not listed will be denied access to the WRE6606. Select Reject to block access to the WRE6606, MAC addresses not listed will be allowed to access the WRE6606
Add a station Mac Address	Enter the MAC addresses of the wireless station that are allowed or denied access to the WRE6606 and click Add . Enter the MAC addresses in a valid MAC address format, that is, six hexadecimal character pairs, for example, 12:34:56:78:9a:bc.
MAC Filter Summary	
Delete	Click the delete icon to remove the MAC address from the list.
MAC Address	This is the MAC address of the wireless station that are allowed or denied access to the WRE6606.
Apply	Click Apply to save your changes back to the WRE6606.
Reset	Click Reset to reload the previous configuration for this screen.

10.8 Wireless LAN Advanced Screen

Use this screen to configure advanced wireless LAN parameters.

Click **Network > Wireless LAN 2.4G** or **Wireless LAN 5G > Advanced**. The screen appears as shown.

Figure 38 Network > Wireless LAN 2.4G/5G > Advanced

The following table describes the labels in this screen.

Table 23 Network > Wireless LAN 2.4G/5G > Advanced

LABEL	DESCRIPTION
RTS/CTS Threshold	Data with its frame size larger than this value will perform the RTS (Request To Send)/CTS (Clear To Send) handshake. Enter a value between 1 and 2347.
Enable Intra-BSS Traffic Blocking	A Basic Service Set (BSS) exists when all communications between wireless clients or between a wireless client and a wired network client go through one access point (AP). Intra-BSS traffic is traffic between wireless clients in the BSS. When Intra-BSS traffic blocking is not enabled, wireless clients can access the wired network and communicate with each other. When Intra-BSS traffic blocking is enabled, wireless clients can still access the wired network but cannot communicate with each other.
Output Power	Set the output power of the WRE6606 in this field. If there is a high density of APs in an area, decrease the output power of the WRE6606 to reduce interference with other APs. Select one of the following 100% , 50% or 25% . See the product specifications for more information on your WRE6606's output power.
HT (High Throughput) Physical Mode	
Guard Interval	Select Auto to increase data throughput. However, this may make data transfer more prone to errors. Select Long to prioritize data integrity. This may be because your wireless network is busy and congested or the WRE6606 is located in an environment prone to radio interference.
Apply	Click Apply to save your changes to the WRE6606.
Reset	Click Reset to reload the previous configuration for this screen.

10.9 Quality of Service (QoS) Screen

The QoS screen allows you to automatically give a service (such as VoIP and video) a priority level.

Click **Network > Wireless LAN 2.4G** or **Wireless LAN 5G > QoS**. The following screen appears.

Figure 39 Network > Wireless LAN 2.4G/5G > QoS

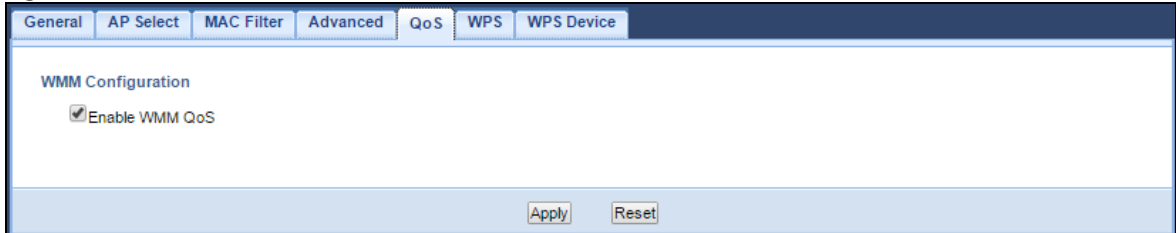

The following table describes the labels in this screen.

Table 24 Network > Wireless LAN 2.4G/5G > QoS

LABEL	DESCRIPTION
Enable WMM QoS	Check this to have the WRE6606 automatically give a service a priority level according to the ToS value in the IP header of packets it sends. WMM QoS (Wifi MultiMedia Quality of Service) gives high priority to voice and video, which makes them run more smoothly.
Apply	Click Apply to save your changes to the WRE6606.
Reset	Click Reset to reload the previous configuration for this screen.

10.10 WPS Screen

Use this screen to enable/disable WPS, view or generate a new PIN and check current WPS status. To open this screen, click **Network > Wireless LAN 2.4G** or **Wireless LAN 5G > WPS** tab.

Note: Wireless clients cannot use WPS to set up a wireless network with the WRE6606 in universal repeater mode.

Figure 40 Network > Wireless LAN 2.4G/5G > WPS (Repeater Mode)

General AP Select MAC Filter Advanced QoS WPS WPS Device

WPS Setup

Enable WPS

Enable PIN

PIN Number : [Generate](#)

WPS Status

Status : Configured

802.11 Mode : 11 a/n/ac

SSID : ZyXELE24502.speed

Security : WPA2-PSK

[Apply](#) [Reset](#)

Figure 41 Network > Wireless LAN 2.4G/5G > WPS (AP Mode)

General MAC Filter Advanced QoS WPS WPS Device Scheduling Guest WLAN

WPS Setup

Enable WPS

Enable PIN

PIN Number : [Generate](#)

WPS Status

Status : Configured [Release_Configuration](#)

802.11 Mode : 11 b/g/n

SSID : ZyXELE24502

Security : WPA2-PSK

[Apply](#) [Reset](#)

The following table describes the labels in this screen.

Table 25 Network > Wireless LAN 2.4G/5G > WPS

LABEL	DESCRIPTION
WPS Setup	
Enable WPS	Select this to enable the WPS feature.
Enable PIN	Select this to enable the PIN number.
PIN Number	This displays a PIN number last time system generated. Click Generate to generate a new PIN number.
WPS Status	
Status	<p>This displays Configured when the WRE6606 has connected to a wireless network using WPS or when Enable WPS is selected and wireless or wireless security settings have been changed. The current wireless and wireless security settings also appear in the screen.</p> <p>This displays Unconfigured if WPS is disabled and there are no wireless or wireless security changes on the WRE6606 or click Release Configuration (AP mode only) to remove the configured wireless and wireless security settings.</p>

Table 25 Network > Wireless LAN 2.4G/5G > WPS (continued)

LABEL	DESCRIPTION
Release Configuration (AP mode only)	This button is only available when the WPS status displays Configured . Click this button to remove all configured wireless and wireless security settings for WPS connections on the WRE6606.
802.11 Mode	This is the 802.11 mode used. Only compliant WLAN devices can associate with the WRE6606.
SSID	This is the name of the wireless network (the WAP3205 v2's first SSID).
Security	This is the type of wireless security employed by the network.
Apply	Click Apply to save your changes back to the WRE6606.
Reset	Click Reset to reload the previous configuration for this screen.

10.11 WPS Device Screen

Use this screen when you want to add a wireless station using WPS. To open this screen, click **Network > Wireless LAN 2.4G** or **Wireless LAN 5G > WPS Device**.

Note: After you click **WPS** on this screen, you have to press a similar button in the wireless station utility within 2 minutes. To add the second wireless station, you have to press these buttons on both device and the wireless station again after the first 2 minutes.

Figure 42 Network > Wireless LAN 2.4G/5G > WPS Device (Repeater Mode)



Figure 43 Network > Wireless LAN 2.4G/5G > WPS Device (AP Mode)

Add Device using WPS

Click WPS below to add WPS stations to your wireless network. Button to add WPS devices to wireless network.

Or input your devices PIN number :

Note :

1. Using WPS requires pressing a button on both your Device and the WRE6606 within 120 seconds.
2. The PIN for your device is normally found within 'Settings'

The following table describes the labels in this screen.

Table 26 Network > Wireless LAN 2.4G/5G > WPS Device

LABEL	DESCRIPTION
WPS	Use this button when you use the PBC (Push Button Configuration) method to configure wireless station's wireless settings. See Section 8.3.1 on page 45 . Click this to start WPS-aware wireless station scanning and the wireless security information synchronization.
Or input your devices PIN number (AP mode only)	Use this button when you use the PIN Configuration method to configure wireless station's wireless settings. See Section 8.3.2 on page 46 . Type the same PIN number generated in the wireless station's utility. Then click Go to associate to each other and perform the wireless security information synchronization.

10.12 Scheduling Screen

Use this screen (available in AP mode only) to set the times your wireless LAN is turned on and off. Wireless LAN scheduling is disabled by default. The wireless LAN can be scheduled to turn on or off on certain days and at certain times. To open this screen, click **Network > Wireless LAN 2.4G** or **Wireless LAN 5G > Scheduling** tab.

Figure 44 Network > Wireless LAN 2.4G/5G > Scheduling

Wireless LAN Scheduling

Wireless LAN Scheduling Enable Disable

WLAN status	Day	For the following times (24-Hour Format)
<input checked="" type="radio"/> On <input type="radio"/> Off	<input checked="" type="checkbox"/> Everyday	00 (hour) 00 (min) ~ 23 (hour) 59 (min)
<input type="radio"/> On <input checked="" type="radio"/> Off	<input type="checkbox"/> Mon	00 (hour) 00 (min) ~ 23 (hour) 59 (min)
<input type="radio"/> On <input checked="" type="radio"/> Off	<input type="checkbox"/> Tue	00 (hour) 00 (min) ~ 23 (hour) 59 (min)
<input type="radio"/> On <input checked="" type="radio"/> Off	<input type="checkbox"/> Wed	00 (hour) 00 (min) ~ 23 (hour) 59 (min)
<input type="radio"/> On <input checked="" type="radio"/> Off	<input type="checkbox"/> Thu	00 (hour) 00 (min) ~ 23 (hour) 59 (min)
<input type="radio"/> On <input checked="" type="radio"/> Off	<input type="checkbox"/> Fri	00 (hour) 00 (min) ~ 23 (hour) 59 (min)
<input type="radio"/> On <input checked="" type="radio"/> Off	<input type="checkbox"/> Sat	00 (hour) 00 (min) ~ 23 (hour) 59 (min)
<input type="radio"/> On <input checked="" type="radio"/> Off	<input type="checkbox"/> Sun	00 (hour) 00 (min) ~ 23 (hour) 59 (min)

Note: For a full day, please specify the begin time 00:00 and end time 23:59

Apply Reset

The following table describes the labels in this screen.

Table 27 Network > Wireless LAN 2.4G/5G > Scheduling

LABEL	DESCRIPTION
Wireless LAN Scheduling	
Wireless LAN Scheduling	Select to enable or disable wireless LAN scheduling.
Scheduling	
WLAN Status	Select On or Off to specify whether the Wireless LAN is turned on or off. This field works in conjunction with the Day and For the following times fields.
Day	Select Everyday or the specific days to turn the Wireless LAN on or off. If you select Everyday you can not select any specific days. This field works in conjunction with the For the following times field.
For the following times (24-Hour Format)	Select a begin time using the first set of hour and minute (min) drop down boxes and select an end time using the second set of hour and minute (min) drop down boxes. If you have chosen On earlier for the WLAN Status the Wireless LAN will turn on between the two times you enter in these fields. If you have chosen Off earlier for the WLAN Status the Wireless LAN will turn off between the two times you enter in these fields.
Apply	Click Apply to save your changes back to the WRE6606.
Reset	Click Reset to reload the previous configuration for this screen.

10.13 Guest WLAN Screen

This screen (available in AP mode only) allows you to enable and configure multiple wireless networks and guest wireless network settings on the WRE6606.

You can configure up to four SSIDs to enable multiple BSSs (Basic Service Sets) on the WRE6606. This allows you to use one access point to provide several BSSs simultaneously. You can then assign varying

security types and to different SSIDs. Wireless clients can use different SSIDs to associate with the same access point.

Figure 45 Network > Wireless LAN 2.4G/5G > Guest WLAN

The following table describes the labels in this screen.

Table 28 Network > Wireless LAN 2.4G/5G > Guest WLAN

LABEL	DESCRIPTION
Guest WLAN Setup	
Guest WLAN	Select Enable to activate the guest wireless LAN. Select Disable to turn it off.
Network Name (SSID)	The SSID (Service Set Identity) identifies the Service Set with which a wireless client is associated. Enter a descriptive name (up to 32 printable characters found on a typical English language keyboard) for the wireless LAN.
Hide SSID	Select this check box to hide the SSID in the outgoing beacon frame so a station cannot obtain the SSID through scanning using a site survey tool.
Guest IP Address	Type an IP address for the devices on the Guest WLAN using this as the gateway IP address.
Guest Subnet Mask	Type the subnet mask for the guest wireless LAN.
Guest Start IP	This field displays the first IP address of guest wireless LAN.
Guest End IP	This field displays the last IP address of guest wireless LAN.
Security	
Security Mode	Select Static WEP , WPA-PSK , and WPA2-PSK to add security on this wireless network. The wireless clients which want to associate to this network must have the same wireless security settings as this device. After you select to use a security, additional options appears in this screen. See Chapter 10 on page 61 for detailed information on different security modes. Or you can select No Security to allow any client to associate this network without authentication. Note: If the WPS function is enabled (default), only No Security and WPA2-PSK are available in this field.
WPA Compatible	This field appears when you choose WPA2-PSK as the Security Mode . Check this field to allow wireless devices using WPA-PSK security mode to connect to your WRE6606.

Table 28 Network > Wireless LAN 2.4G/5G > Guest WLAN

LABEL	DESCRIPTION
Pre-Shared Key	WPA-PSK/WPA2-PSK uses a simple common password for authentication. Type a pre-shared key from 8 to 63 case-sensitive keyboard characters.
Group Key Update Timer	The Group Key Update Timer is the rate at which the AP sends a new group key out to all clients. The default is 3600 seconds (60 minutes).
Apply	Click Apply to save your changes back to the WRE6606.
Reset	Click Reset to reload the previous configuration for this screen.

CHAPTER 11

LAN

11.1 Overview

This screen allows you to assign the WRE6606 a fixed or dynamic management IP address. The default IP address of the WRE6606 is 192.168.1.2. Alternatively, you can connect to the WRE6606 using the default domain name, `http://zyxelsetup` or `http://zyxelsetup.local`.

11.2 LAN IP Screen

Use this screen to change the WRE6606's management IP address and configure the DNS server information that the WRE6606 sends to the DHCP clients. Click **Network > LAN**.

Note: If you change the IP address of the WRE6606 in the screen below, you will need to log into the WRE6606 again using the new IP address.

Figure 46 Network > LAN > IP

The screenshot shows the 'IP' configuration page. The 'LAN TCP/IP' section has 'Get from DHCP Server' selected. The 'IP Address' field contains '192.168.1.2', 'IP Subnet Mask' contains '255.255.255.0', and 'Default Gateway' is empty. The 'DNS Assignment' section has 'First DNS Server' and 'Second DNS Server' both set to 'From ISP' with empty input fields. 'Apply' and 'Reset' buttons are at the bottom.

The following table describes the labels in this screen.

Table 29 Network > LAN > IP

LABEL	DESCRIPTION
LAN TCP/IP	
Get from DHCP Server	Select this to have the WRE6606 get a dynamic IP address from a DHCP server.
Use Defined LAN IP Address	Click this to enable the manual IP configuration.

Table 29 Network > LAN > IP (continued)

LABEL	DESCRIPTION
IP Address	Enter the IP address of your WRE6606 in dotted decimal notation.
IP Subnet Mask	Enter the subnet mask of your WRE6606 in dotted decimal notation.
Default Gateway	Enter the gateway of your WRE6606 in dotted decimal notation.
DNS Assignment	
First DNS Server Second DNS Server	<p>Select From ISP if your ISP or router to which the WRE6606 connects dynamically assigns DNS server information (and the WRE6606's IP address). The field to the right displays the (read-only) DNS server IP address that the ISP assigns.</p> <p>Select User-Defined if you have the IP address of a DNS server. Enter the DNS server's IP address in the field to the right.</p> <p>Select None if you do not want to configure DNS servers. If you do not configure a DNS server, you must know the IP address of a computer in order to access it.</p>
Apply	Click Apply to save your changes back to the WRE6606.
Reset	Click Reset to reload the previous configuration for this screen.

CHAPTER 12

One Connect

12.1 Overview

One Connect is a Zyxel-proprietary feature. It complies with the IEEE 1905.1 standard and allows auto-detection and auto-configuration.

If your wireless router supports Zyxel One Connect, WRE6606 for example, you can download and install the Zyxel One Connect App in your mobile device to check the connection status, do speed test, turn on or turn off the devices in your network, block or allow a device's access and set up a guest Wi-Fi network from the mobile device. You can even use the App to access the WRE6606's web configurator. The mobile device with the App installed must be connected to the WRE6606 wirelessly.

Figure 47 Zyxel One Connect App

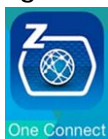

12.1.1 What You Can Do

Use the **One Connect** screen to enable or disable Wi-Fi auto-configuration ([Section 12.2 on page 80](#)).

12.2 One Connect Screen

Use this screen to enable or disable Wi-Fi auto-configuration on the WRE6606.

Click **Configuration > Network > OneConnect** to open the following screen.

Figure 48 Configuration > Network > OneConnect

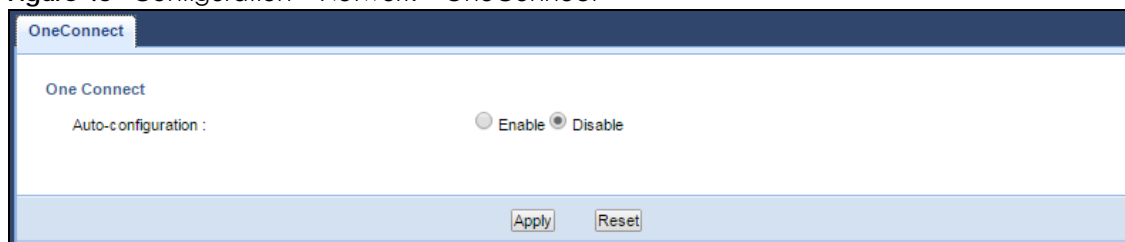

The following table describes the labels in this screen.

Table 30 Configuration > Network > OneConnect

LABEL	DESCRIPTION
One Connect	
Auto-configuration	Select Enable to allow the WRE6606 to automatically update the wireless settings on the APs or wireless repeaters (which also support Zyxel One Connect) in its network. Select Disable to turn this feature off if you want to have the APs or repeaters in the network use different wireless settings.
Apply	Click Apply to save your changes back to the WRE6606.
Reset	Click Reset to reload the previous configuration for this screen.

CHAPTER 13

Maintenance

13.1 Overview

This chapter provides information on the **Maintenance** screen.

13.2 What You Can Do

- Use the **General** screen to set the system and domain names ([Section 13.3 on page 82](#)).
- Use the **Password** screen to set the password ([Section 13.4 on page 83](#)).
- Use the **Time** screen to change your WRE6606's time and date ([Section 13.5 on page 83](#)).
- Use the **Firmware Upgrade** screen to update firmware ([Section 13.6 on page 85](#)).
- Use the **Backup Restore** screen to backup and restore device configurations ([Section 13.7 on page 87](#)).
- Use the **Restart** screen to reboot the WRE6606 without turning the power off ([Section 13.8 on page 89](#)).
-
- Use the **System Mode** screen to select how you want to use your WRE6606 ([Section 13.9 on page 89](#)).

13.3 General

Use this screen to set the system and domain names and the timeout period of the management session. Click **Maintenance > General**. The following screen displays.

Figure 49 Maintenance > General

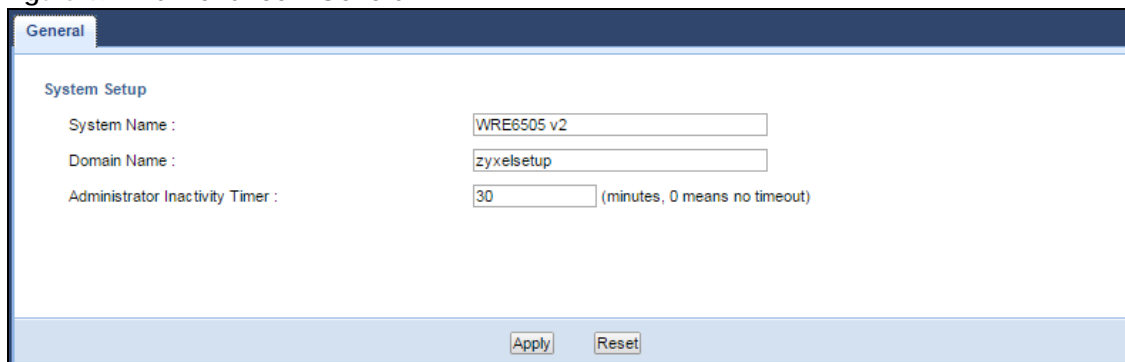

The screenshot shows a web interface for the 'General' maintenance screen. At the top, there is a tab labeled 'General'. Below it, the section is titled 'System Setup'. There are three input fields: 'System Name' with the value 'WRE6505 v2', 'Domain Name' with the value 'zyxelsetup', and 'Administrator Inactivity Timer' with the value '30' and a note '(minutes, 0 means no timeout)'. At the bottom of the form, there are two buttons: 'Apply' and 'Reset'.

The following table describes the labels in this menu.

Table 31 Maintenance > General

LABEL	DESCRIPTION
System Name	Enter a descriptive name to identify the WRE6606 in an Ethernet network.
Domain Name	This is the domain name of the WRE6606.
Administrator Inactivity Timer	Type how many minutes a management session can be left idle before the session times out. After it times out you have to log in with your password again. Very long idle timeouts may have security risks. A value of "0" means a management session never times out, no matter how long it has been left idle (not recommended).
Apply	Click Apply to save your changes back to the WRE6606.
Reset	Click Reset to reload the previous configuration for this screen.

13.4 System Password Screen

Use this screen to set the web configurator password. Click **Maintenance > System**. The following screen displays.

Figure 50 Maintenance > Password

The screenshot shows a web interface for password setup. It features a header 'Password Setup' and three text input fields for 'Old Password', 'New Password', and 'Retype to Confirm'. At the bottom, there are two buttons: 'Apply' and 'Reset'.

The following table describes the labels in this screen.

Table 32 Maintenance > System > Password

LABEL	DESCRIPTION
Old Password	Type the default password or the existing password you use to access the system in this field.
New Password	Type your new system password (up to 30 characters). Note that as you type a password, the screen displays an asterisk (*) for each character you type.
Retype to Confirm	Type the new password again in this field.
Apply	Click Apply to save your changes back to the WRE6606.
Reset	Click Reset to reload the previous configuration for this screen.

13.5 Time Screen

Use this screen to configure the WRE6606's time based on your local time zone. To change your WRE6606's time and date, click **Maintenance > Time**. The screen appears as shown.

Figure 51 Maintenance > Time

The following table describes the labels in this screen.

Table 33 Maintenance > Time

LABEL	DESCRIPTION
Current Time and Date	
Current Time	This field displays the time of your WRE6606. Each time you reload this page, the WRE6606 synchronizes the time with the time server.
Current Date	This field displays the date of your WRE6606. Each time you reload this page, the WRE6606 synchronizes the date with the time server.
Manual	Select this radio button to enter the time and date manually. If you configure a new time and date, Time Zone and Daylight Saving at the same time, the new time and date you entered has priority and the Time Zone and Daylight Saving settings do not affect it.
New Time (hh:mm:ss)	This field displays the last updated time from the time server or the last time configured manually. When you select Manual , enter the new time in this field and then click Apply .
New Date (yyyy/mm/dd)	This field displays the last updated date from the time server or the last date configured manually. When you select Manual , enter the new date in this field and then click Apply .
Get from Time Server	Select this radio button to have the WRE6606 get the time and date from the time server you specified below.
Auto	Select Auto to have the WRE6606
User Defined Time Server Address	Select User Defined Time Server Address and enter the IP address or URL (up to 20 extended ASCII characters in length) of your time server. Check with your ISP/network administrator if you are unsure of this information.

Table 33 Maintenance > Time (continued)

LABEL	DESCRIPTION
Time Zone Setup	
Time Zone	Choose the time zone of your location. This will set the time difference between your time zone and Greenwich Mean Time (GMT).
Daylight Savings	Daylight saving is a period from late spring to early fall when many countries set their clocks ahead of normal local time by one hour to give more daytime light in the evening. Select this option if you use Daylight Saving Time.
Start Date	Configure the day and time when Daylight Saving Time starts if you selected Daylight Savings . The at field uses the 24 hour format. Here are a couple of examples: Daylight Saving Time starts in most parts of the United States on the second Sunday of March. Each time zone in the United States starts using Daylight Saving Time at 2 A.M. local time. So in the United States you would select Second, Sunday, March and select 2 in the at field. Daylight Saving Time starts in the European Union on the last Sunday of March. All of the time zones in the European Union start using Daylight Saving Time at the same moment (1 A.M. GMT or UTC). So in the European Union you would select Last, Sunday, March . The time you select in the at field depends on your time zone. In Germany for instance, you would select 2 because Germany's time zone is one hour ahead of GMT or UTC (GMT+1).
End Date	Configure the day and time when Daylight Saving Time ends if you selected Daylight Savings . The at field uses the 24 hour format. Here are a couple of examples: Daylight Saving Time ends in the United States on the first Sunday of November. Each time zone in the United States stops using Daylight Saving Time at 2 A.M. local time. So in the United States you would select First, Sunday, November and select 2 in the at field. Daylight Saving Time ends in the European Union on the last Sunday of October. All of the time zones in the European Union stop using Daylight Saving Time at the same moment (1 A.M. GMT or UTC). So in the European Union you would select Last, Sunday, October . The time you select in the at field depends on your time zone. In Germany for instance, you would select 2 because Germany's time zone is one hour ahead of GMT or UTC (GMT+1).
Apply	Click Apply to save your changes back to the WRE6606.
Reset	Click Reset to begin configuring this screen afresh.

13.6 Firmware Upgrade Screen

Find firmware at www.zyxel.com in a file that (usually) uses the system model name with a "*.bin" extension, e.g., "WRE6606.bin". The upload process uses HTTP (Hypertext Transfer Protocol) and may take up to two minutes. After a successful upload, the system will reboot.

Click **Maintenance > Firmware Upgrade**. Follow the instructions in this screen to upload firmware to your WRE6606.

Figure 52 Maintenance > Firmware Upgrade

The following table describes the labels in this screen.

Table 34 Maintenance > Firmware Upgrade

LABEL	DESCRIPTION
Firmware Upgrade	
File Path	Click Select file to find the .bin file you want to upload. Remember that you must decompress compressed (.zip) files before you can upload them.
Upload	Click Upload to begin the upload process. This process may take up to two minutes.
On-line Firmware Upgrade	
Check for Latest Firmware Now	The following fields display when you click this button.
You are currently using firmware version:	The firmware version consists of the trunk version number, model code, and release number. For example, V1.00(AAAG.5) means V1.00 is the trunk number, AAAG represents WRE6606, and 5 means the fifth release.
The Latest Firmware Version	Compare the release number in the previous field with the release number in this one to see if you have the latest firmware. In this example, V1.00(AAAG.5), the numbers are the same (5), so the WRE6606 already has the latest firmware.
Release Date	The date the firmware was issued is shown in year-month-date format.
Release Note	The release note shows what has changed (new features, bug fixes, known issues) in this firmware version. Check the Release Note before deciding to use new firmware.
Size	This is the size of the firmware in bytes. 15073234 is about 15 MB.
Do_Firmware_Upgrade	Click this button to download and upgrade the new firmware to the WRE6606.

Note: Do not turn off the WRE6606 while firmware upload is in progress!

After you see the **Firmware Upgrading** screen, wait until the upgrade process is complete.

Figure 53 Firmware Upgrading



The WRE6606 automatically restarts in this time causing a temporary network disconnect. In some operating systems, you may see the following icon on your desktop.

Figure 54 Network Temporarily Disconnected

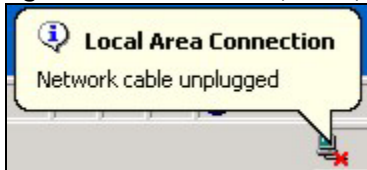

After the WRE6606 restarts, the **Upgrade Accomplished** screen appears.

Figure 55 Upgrade Accomplished

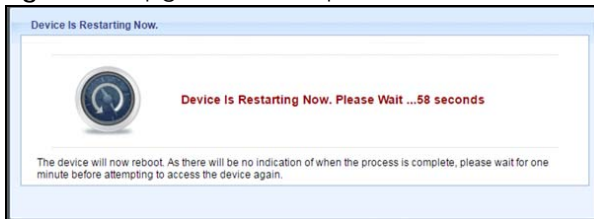

Refresh the web page and log in again and check your new firmware version in the **Status** screen.

13.7 Backup / Restore Screen

Click **Maintenance > Backup/Restore**. Information related to factory defaults, backup configuration, and restoring configuration appears as shown next.

Figure 56 Maintenance > Backup/Restore

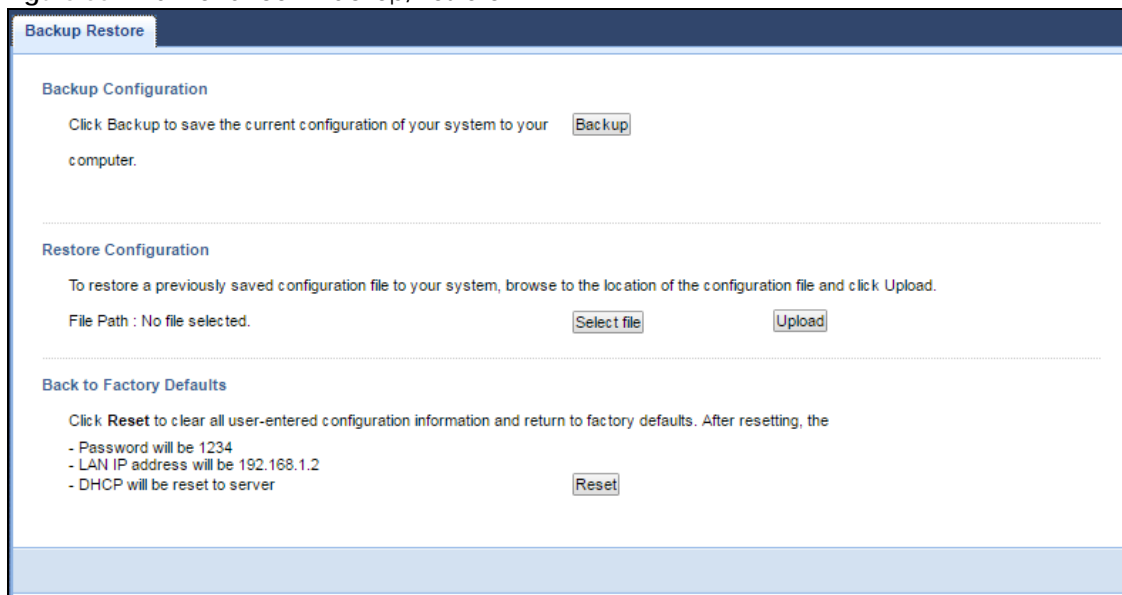

13.7.1 Backup Configuration

Backup configuration allows you to back up (save) the WRE6606's current configuration to a file on your computer. Once your WRE6606 is configured and functioning properly, it is highly recommended that you back up your configuration file before making configuration changes. The backup configuration file will be useful in case you need to return to your previous settings.

Click **Backup** to save the WRE6606's current configuration to your computer.

13.7.2 Restore Configuration

Restore configuration allows you to upload a new or previously saved configuration file from your computer to your WRE6606.

Table 35 Maintenance Restore Configuration

LABEL	DESCRIPTION
File Path	Click Select file to find the file you want to upload. Remember that you must decompress compressed (.ZIP) files before you can upload them.
Upload	Click Upload to begin the upload process.

Note: Do not turn off the WRE6606 while configuration file upload is in progress.

After you see a "configuration upload successful" screen, you must then wait one minute before logging into the WRE6606 again.

The WRE6606 automatically restarts in this time causing a temporary network disconnect. In some operating systems, you may see the following icon on your desktop.

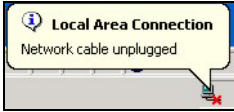
Figure 57 Temporarily Disconnected

If you uploaded the default configuration file you may need to change the IP address of your computer to be in the same subnet as that of the default WRE6606 IP address (192.168.1.2). Refer to your operating system's help files for details on how to set up your computer's IP address.

13.7.3 Back to Factory Defaults

Click the **Reset** button to clear all user-entered configuration information and return the WRE6606 to its factory defaults. The following warning screen appears.

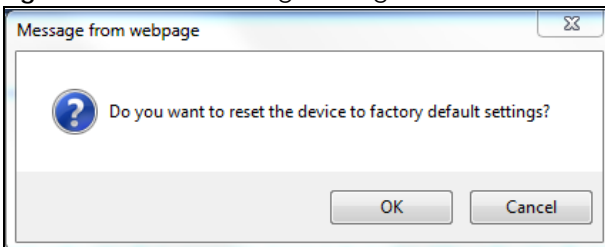
Figure 58 Reset Warning Message

You can also press the **WPS** button (see [Section 1.4 on page 12](#)) on the front panel for more than 10 seconds to reset the factory defaults of your WRE6606. Refer to [Section 1.4 on page 12](#) for more information on the resetting the WRE6606.

13.8 Restart Screen

System restart allows you to reboot the WRE6606 without turning the power off. Click **Maintenance > Restart**. The following screen displays. Click **Restart** to have the WRE6606 reboot. This does not affect the WRE6606's configuration.

Figure 59 Maintenance > Restart

13.9 System Mode

Use this screen to change the operating mode of the WRE6606. For further information on system operating mode, see [Section 3.1.1 on page 18](#).

Figure 60 Maintenance > System Mode



The following table describes the labels in this menu.

Table 36 Maintenance > System Mode

LABEL	DESCRIPTION
Normal mode	The default WPS behavior, both 2.4 GHz and 5 GHz bands are supported in up and down broadcasting.
Range boost mode	Select this option to set the WRE6606 to Range boost mode --the 2.4 GHz band is supported in up broadcasting, while the 5 GHz band is supported in down broadcasting.
Speed boost mode	Select this option to set the WRE6606 to Speed boost mode --the 5 GHz band is supported in up broadcasting,, while the 2.4 GHz band is supported in down broadcasting,.
Apply	Click Apply to save your changes back to the WRE6606.
Reset	Click Reset to reload the previous configuration for this screen.

13.9.1 Repeater Broadcasting Behavior

The WRE6606 in repeater mode enables you to extend the range of your dual-band AP or wireless router to eliminate "dead spots" in your wireless network. You can choose from normal mode, range boost, or speed boost modes.

The following terms are used to describe the broadcasting behavior in repeater mode:

- Up: The connection from the WRE6606 (in repeater mode) to the AP or wireless router

- Down: The connection from the WRE6606 (in repeater mode) to a client

Figure 61 Repeater Mode with Up and Down Broadcasting

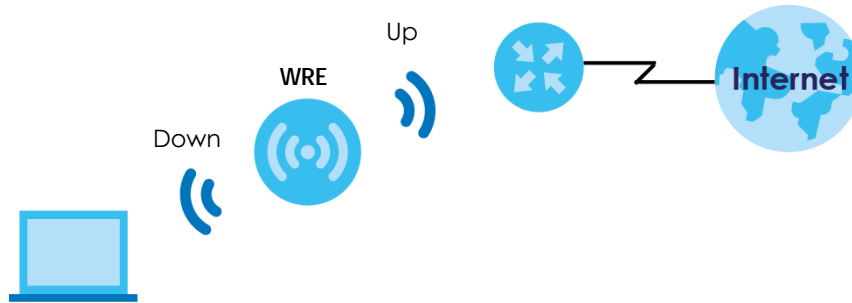

13.9.1.1 Normal Mode

In normal mode, both Down and Up broadcasting are supported for both 2.4 GHz and 5 GHz bands.

Figure 62 System Mode: Normal mode



13.9.1.2 Range Boost Mode

In range boost mode, the 2.4 GHz band is supported on the Up behavior, while both 2.4G and 5 GHz bands are supported on the Down behavior.

Figure 63 System Mode: Range Boost Mode

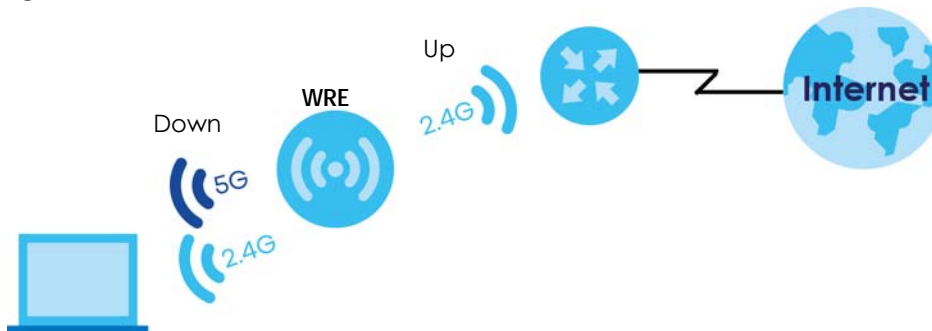

13.9.1.3 Speed Boost Mode

In speed boost mode, the 5 GHz band is supported on the Up behavior, while both 2.4G and 5 GHz bands are supported on the Down behavior.

Figure 64 System Mode: Speed Boost Mode



CHAPTER 14

Troubleshooting

This chapter offers some suggestions to solve problems you might encounter. The potential problems are divided into the following categories.

- [Power, Hardware Connections, and LEDs](#)
- [WRE6606 Access and Login](#)
- [Internet Access](#)
- [Wireless Problems](#)
- [Resetting the WRE6606 to Its Factory Defaults](#)

14.1 Power, Hardware Connections, and LEDs

[The WRE6606 does not turn on. None of the LEDs turn on.](#)

- 1 Make sure the WRE6606 is plugged in to an appropriate power source. Make sure the power source is turned on.
- 2 Disconnect and re-connect the WRE6606.
- 3 Remove the WRE6606 from the outlet. Then connect an electrical device that you know works into the same power outlet. This checks the status of the power outlet.
- 4 If the problem continues, contact the vendor.

[One of the LEDs does not behave as expected.](#)

- 1 Make sure you understand the normal behavior of the LED. See [Section 1.3 on page 10](#).
- 2 Make sure you understand how the LEDs are enabled or disabled. See [Section 1.3 on page 10](#).
- 3 Check the hardware connections. See the Quick Start Guide.
- 4 Inspect your cables for damage. Contact the vendor to replace any damaged cables.
- 5 Disconnect and re-connect the WRE6606.
- 6 If the problem continues, contact the vendor.

14.2 WRE6606 Access and Login

I forgot the password.

- 1 The default password is **1234**.
- 2 If this does not work, you have to reset the device to its factory defaults. See [Section 14.4 on page 96](#).

I cannot see or access the **Login** screen in the Web Configurator.

- 1 Make sure you are using the correct address.
 - The default web address (URL) of the WRE6606 is **http://zyxelsetup** (Windows) or **http://zyxelsetup.local** (Mac).
- 2 Check the hardware connections, and make sure the LEDs are behaving as expected. See the Quick Start Guide.
- 3 Make sure your Internet browser does not block pop-up windows and has JavaScript and Java enabled.
- 4 Reset the device to its factory defaults, and try to access the WRE6606 with the default address.
- 5 If the problem continues, contact the network administrator or vendor, or try one of the advanced suggestions.

Advanced Suggestions

- If your computer is connected wirelessly, use a computer that is connected to a **LAN/ETHERNET** port.

I can see the **Login** screen, but I cannot log in to the WRE6606.

- 1 Make sure you have entered the password correctly. The default password is **1234**.
- 2 This can happen when you fail to log out properly from your last session. Try logging in again after 5 minutes.
- 3 Disconnect and re-connect the WRE6606.
- 4 If this does not work, you have to reset the device to its factory defaults. See [Section 14.4 on page 96](#).

14.3 Internet Access

I cannot access the Internet.

- 1 Check the hardware connections, and make sure the LEDs are behaving as expected. See the Quick Start Guide.
- 2 Try to connect directly to the AP. If you can access the Internet, check that the WRE6606 (repeater mode) has associated with the AP by checking the **Status** screen. See [Section 6.4 on page 31](#).
- 3 If you are trying to access the Internet wirelessly, make sure the wireless settings in the wireless client are the same as the settings in the AP.
- 4 Disconnect all the cables from your device, and follow the directions in the Quick Start Guide again.
- 5 If the problem continues, contact the network administrator or vendor.

I cannot access the Internet anymore. I had access to the Internet (with the WRE6606 in repeater mode), but my Internet connection is not available anymore.

- 1 Check the hardware connections, and make sure the LEDs are behaving as expected. See the Quick Start Guide and [Section 1.3 on page 10](#).
- 2 Reboot the WRE6606.
- 3 Try to connect directly to the AP. If you can access the Internet, check that the WRE6606 (repeater mode) has associated with the AP by checking the **Status** screen. See [Section 6.4 on page 31](#).
- 4 If the problem continues, contact the network administrator or vendor.

The Internet connection is slow or intermittent.

- 1 There might be a lot of traffic on the network. Look at the LEDs, and check [Section 1.3 on page 10](#). If the WRE6606 is sending or receiving a lot of information, try closing some programs that use the Internet, especially peer-to-peer applications.
- 2 Check the signal strength. If the signal strength is low, try moving the WRE6606 closer to the AP if possible, and look around to see if there are any devices that might be interfering with the wireless network (for example, microwaves, other wireless networks, and so on). If there are, move further away from them.
- 3 Reboot the WRE6606.
- 4 If the problem continues, contact the network administrator or vendor, or try one of the advanced suggestions.

Advanced Suggestion

- Check the settings for QoS. If it is disabled, you might consider activating it.

14.4 Wireless Problems

I cannot access the WRE6606 (in AP or repeater mode) or ping any computer from the WLAN.

- 1 Make sure the wireless LAN is enabled on the WRE6606.
- 2 Make sure the wireless adapter on the wireless station is working properly.
- 3 Make sure the wireless adapter installed on your computer is IEEE 802.11 compatible and supports the same wireless standard as the WRE6606.
- 4 Make sure your computer (with a wireless adapter installed) is within the transmission range of the WRE6606.
- 5 Check that both the WRE6606 and your wireless station are using the same wireless and wireless security settings, and that both the WRE6606 and the AP are using the same wireless and wireless security settings.
- 6 Make sure traffic between the WLAN and the LAN is not blocked by the MAC Address List of the WRE6606. See [Section 10.7 on page 69](#).

My wireless device keeps asking me for my Wi-Fi network password, and I am sure I have entered the correct password.

You may be at the edge of the Wi-Fi network. Move the WRE6606 closer to the wireless router or AP or move your wireless device closer to the WRE6606 for a more stable wireless connection.

Can I set up the WRE6606 in Repeater mode if I connect it to the router or access point with an Ethernet cable?

No. The WRE6606 only connects wirelessly to the router or AP when it is in Repeater mode. If the WRE6606 is in Access Point mode, connect it to the router using an Ethernet cable.

I enabled a wireless MAC filter or wireless firewall rule on my router. What should I do when installing the WRE6606 (in repeater mode)?

When a client device connects through the WRE6606 to your router, the MAC address of the client device shown on the router is translated to another MAC address. If your router's MAC filter or firewall is enabled, the client device can connect to the WRE6606 but cannot get an IP address from the router and cannot access the Internet.

To allow your client device to receive an IP address from the router and access the Internet, you must provide the translated MAC address to the router.

- 1 Log into your router and disable the MAC filter and firewall. For more information on this, see your router's documentation.
- 2 Turn on the WRE6606 and let all your wireless client devices connect to the WRE6606 wireless network. Check that the 2.4 G and/or 5G LEDs on the WRE6606 are lit.
- 3 Log into your WRE6606, go to the **Status** screen and note down the MAC Addresses in the 2.4G and 5G **Association List**.
- 4 Log into your router again, add the MAC addresses from the 2.4G and 5G **Association List** to the router's MAC filter table and allow the MAC addresses to access the network.
- 5 Enable the router's MAC filter and firewall again.

14.5 Resetting the WRE6606 to Its Factory Defaults

If you reset the WRE6606, you lose all of the changes you have made. The WRE6606 re-loads its default settings, and the password resets to **1234**. You have to make all of your changes again.

[Reset the WRE6606 if you forget your password or IP address, or you cannot access the Web Configurator.](#)

- 1 Make sure the power LED is on.
- 2 Press the **WPS** button for longer than 10 seconds, the Power LED begins to blink, to set the WRE6606 back to its factory-default configuration.
OR
- 3 Click **Maintenance > Backup Restore > Restore** and then click **Reset**.

If the WRE6606 restarts automatically, wait for the WRE6606 to finish restarting, and log in to the Web Configurator. The password is **1234**.

If the WRE6606 does not restart automatically, disconnect and reconnect the WRE6606'. Then, follow the directions above again.

APPENDIX A

Customer Support

In the event of problems that cannot be solved by using this manual, you should contact your vendor. If you cannot contact your vendor, then contact a Zyxel office for the region in which you bought the device.

See <http://www.zyxel.com/homepage.shtml> and also http://www.zyxel.com/about_zyxel/zyxel_worldwide.shtml for the latest information.

Please have the following information ready when you contact an office.

Required Information

- Product model and serial number.
- Warranty Information.
- Date that you received your device.
- Brief description of the problem and the steps you took to solve it.

Corporate Headquarters (Worldwide)

Taiwan

- Zyxel Communications Corporation
- <http://www.zyxel.com>

Asia

China

- Zyxel Communications (Shanghai) Corp.
- Zyxel Communications (Beijing) Corp.
- Zyxel Communications (Tianjin) Corp.
- <http://www.zyxel.cn>

India

- Zyxel Technology India Pvt Ltd
- <http://www.zyxel.in>

Kazakhstan

- Zyxel Kazakhstan
- <http://www.zyxel.kz>

Korea

- Zyxel Korea Corp.
- <http://www.zyxel.kr>

Malaysia

- Zyxel Malaysia Sdn Bhd.
- <http://www.zyxel.com.my>

Pakistan

- Zyxel Pakistan (Pvt.) Ltd.
- <http://www.zyxel.com.pk>

Philippines

- Zyxel Philippines
- <http://www.zyxel.com.ph>

Singapore

- Zyxel Singapore Pte Ltd.
- <http://www.zyxel.com.sg>

Taiwan

- Zyxel Communications Corporation
- <http://www.zyxel.com/tw/zh/>

Thailand

- Zyxel Thailand Co., Ltd
- <http://www.zyxel.co.th>

Vietnam

- Zyxel Communications Corporation-Vietnam Office
- <http://www.zyxel.com/vn/vi>

Europe

Austria

- Zyxel Deutschland GmbH
- <http://www.zyxel.de>

Belarus

- Zyxel BY
- <http://www.zyxel.by>

Belgium

- Zyxel Communications B.V.
- <http://www.zyxel.com/be/nl/>
- <http://www.zyxel.com/be/fr/>

Bulgaria

- Zyxel България
- <http://www.zyxel.com/bg/bg/>

Czech Republic

- Zyxel Communications Czech s.r.o
- <http://www.zyxel.cz>

Denmark

- Zyxel Communications A/S
- <http://www.zyxel.dk>

Estonia

- Zyxel Estonia
- <http://www.zyxel.com/ee/et/>

Finland

- Zyxel Communications
- <http://www.zyxel.fi>

France

- Zyxel France
- <http://www.zyxel.fr>

Germany

- Zyxel Deutschland GmbH
- <http://www.zyxel.de>

Hungary

- Zyxel Hungary & SEE
- <http://www.zyxel.hu>

Italy

- Zyxel Communications Italy
- <http://www.zyxel.it/>

Latvia

- Zyxel Latvia
- <http://www.zyxel.com/lv/lv/homepage.shtml>

Lithuania

- Zyxel Lithuania
- <http://www.zyxel.com/lt/lt/homepage.shtml>

Netherlands

- Zyxel Benelux
- <http://www.zyxel.nl>

Norway

- Zyxel Communications
- <http://www.zyxel.no>

Poland

- Zyxel Communications Poland
- <http://www.zyxel.pl>

Romania

- Zyxel Romania
- <http://www.zyxel.com/ro/ro>

Russia

- Zyxel Russia
- <http://www.zyxel.ru>

Slovakia

- Zyxel Communications Czech s.r.o. organizacna zlozka
- <http://www.zyxel.sk>

Spain

- Zyxel Communications ES Ltd
- <http://www.zyxel.es>

Sweden

- Zyxel Communications
- <http://www.zyxel.se>

Switzerland

- Studerus AG

- <http://www.zyxel.ch/>

Turkey

- Zyxel Turkey A.S.
- <http://www.zyxel.com.tr>

UK

- Zyxel Communications UK Ltd.
- <http://www.zyxel.co.uk>

Ukraine

- Zyxel Ukraine
- <http://www.ua.zyxel.com>

Latin America

Argentina

- Zyxel Communication Corporation
- <http://www.zyxel.com/ec/es/>

Brazil

- Zyxel Communications Brasil Ltda.
- <https://www.zyxel.com/br/pt/>

Ecuador

- Zyxel Communication Corporation
- <http://www.zyxel.com/ec/es/>

Middle East

Israel

- Zyxel Communication Corporation
- <http://il.zyxel.com/homepage.shtml>

Middle East

- Zyxel Communication Corporation
- <http://www.zyxel.com/me/en/>

North America

USA

- Zyxel Communications, Inc. - North America Headquarters
- <http://www.zyxel.com/us/en/>

Oceania

Australia

- Zyxel Communications Corporation
- <http://www.zyxel.com/au/en/>

Africa

South Africa

- Nology (Pty) Ltd.
- <http://www.zyxel.co.za>

APPENDIX B

Legal Information

Copyright

Copyright © 2018 by Zyxel Communications Corporation.

The contents of this publication may not be reproduced in any part or as a whole, transcribed, stored in a retrieval system, translated into any language, or transmitted in any form or by any means, electronic, mechanical, magnetic, optical, chemical, photocopying, manual, or otherwise, without the prior written permission of Zyxel Communications Corporation.

Published by Zyxel Communications Corporation. All rights reserved.

Disclaimer

Zyxel does not assume any liability arising out of the application or use of any products, or software described herein. Neither does it convey any license under its patent rights nor the patent rights of others. Zyxel further reserves the right to make changes in any products described herein without notice. This publication is subject to change without notice.

Regulatory Notice and Statement

UNITED STATES of AMERICA



The following information applies if you use the product within USA area.

FCC EMC Statement

- The device complies with Part 15 of FCC rules. Operation is subject to the following two conditions:
 - (1) This device may not cause harmful interference, and
 - (2) This device must accept any interference received, including interference that may cause undesired operation.
- Changes or modifications not expressly approved by the party responsible for compliance could void the user's authority to operate the device.
- This product has been tested and complies with the specifications for a Class B digital device, pursuant to Part 15 of the FCC Rules. These limits are designed to provide reasonable protection against harmful interference in a residential installation. This device generates, uses, and can radiate radio frequency energy and, if not installed and used according to the instructions, may cause harmful interference to radio communications. However, there is no guarantee that interference will not occur in a particular installation.
- If this device does cause harmful interference to radio or television reception, which is found by turning the device off and on, the user is encouraged to try to correct the interference by one or more of the following measures:
 - Reorient or relocate the receiving antenna
 - Increase the separation between the devices
 - Connect the equipment to an outlet other than the receiver's
 - Consult a dealer or an experienced radio/TV technician for assistance

The following information applies if you use the product with RF function within USA area.

FCC Radiation Exposure Statement

- This device complies with FCC RF radiation exposure limits set forth for an uncontrolled environment.
- This transmitter must be at least 20 cm from the user and must not be co-located or operating in conjunction with any other antenna or transmitter.
- Operation of this device is restricted to indoor use only, except for relevant user's manual mention that this device can be installed into the external environment.

CANADA

The following information applies if you use the product within Canada area

Industry Canada ICES Statement

CAN ICES-3 (B)/NMB-3(B)

Industry Canada CS-03 Statement

- This product meets the applicable Innovation, Science and Economic Development Canada technical specifications.

- The Ringer Equivalence Number (REN) indicates the maximum number of devices allowed to be connected to a telephone interface. The termination of an interface may consist of any combination of devices subject only to the requirement that the sum of the RENs of all the devices not exceed five.

Déclaration de conformité

- Le présent produit est conforme aux spécifications techniques applicables d'Innovation, Sciences et Développement économique Canada.
- L'indice d'équivalence de la sonnerie (IES) sert à indiquer le nombre maximal de dispositifs qui peuvent être raccordés à une interface téléphonique. La terminaison d'une interface peut consister en une combinaison quelconque de dispositifs, à la seule condition que la somme des IES de tous les dispositifs n'exécède pas cinq.

Industry Canada RSS-GEN & RSS-247 statement

- This device complies with Industry Canada license-exempt RSS standard(s). Operation is subject to the following two conditions: (1) this device may not cause interference, and (2) this device must accept any interference, including interference that may cause undesired operation of the device.
- This radio transmitter has been approved by Industry Canada to operate with the antenna types listed below with the maximum permissible gain and required antenna impedance for each antenna type indicated. Antenna types not included in this list, having a gain greater than the maximum gain indicated for that type, are strictly prohibited for use with this device.

If the product with 5G wireless function operating in 5150-5250 MHz and 5725-5850 MHz, the following attention must be paid,

- The device for operation in the band 5150-5250 MHz is only for indoor use to reduce the potential for harmful interference to co-channel mobile satellite systems.
- For devices with detachable antenna(s), the maximum antenna gain permitted for devices in the band 5725-5850 MHz shall be such that the equipment still complies with the e.i.r.p. limits specified for point-to-point and non-point-to-point operation as appropriate; and
- The worst-case tilt angle(s) necessary to remain compliant with the e.i.r.p. elevation mask requirement set forth in Section 6.2.2(3) of RSS 247 shall be clearly indicated.

If the product with 5G wireless function operating in 5250-5350 MHz and 5470-5725 MHz, the following attention must be paid.

- For devices with detachable antenna(s), the maximum antenna gain permitted for devices in the bands 5250-5350 MHz and 5470-5725 MHz shall be such that the equipment still complies with the e.i.r.p. limit.
- Le présent appareil est conforme aux CNR d'Industrie Canada applicables aux appareils radio exempts de licence. L'exploitation est autorisée aux deux conditions suivantes: (1) l'appareil ne doit pas produire de brouillage, et (2) l'utilisateur de l'appareil doit accepter tout brouillage radioélectrique subi, même si le brouillage est susceptible d'en compromettre le fonctionnement.
- Le présent émetteur radio de modèle s'il fait partie du matériel de catégoriel) a été approuvé par Industrie Canada pour fonctionner avec les types d'antenne énumérés ci-dessous et ayant un gain admissible maximal et l'impédance requise pour chaque type d'antenne. Les types d'antenne non inclus dans cette liste, ou dont le gain est supérieur au gain maximal indiqué, sont strictement interdits pour l'exploitation de l'émetteur.

Lorsque la fonction sans fil 5G fonctionnant en 5150-5250 MHz and 5725-5850 MHz est activée pour ce produit , il est nécessaire de porter une attention particulière aux choses suivantes

- Les dispositifs fonctionnant dans la bande 5150-5250 MHz sont réservés uniquement pour une utilisation à l'intérieur afin de réduire les risques de brouillage préjudiciable aux systèmes de satellites mobiles utilisant les mêmes canaux;
- Pour les dispositifs munis d'antennes amovibles, le gain maximal d'antenne permis (pour les dispositifs utilisant la bande de 5 725 à 5 850 MHz) doit être conforme à la limite de la p.i.r.e. spécifiée pour l'exploitation point à point et l'exploitation non point à point, selon le cas;
- Les pires angles d'inclinaison nécessaires pour rester conforme à l'exigence de la p.i.r.e. applicable au masque d'élevation, et énoncée à la section 6.2.2.3) du CNR-247, doivent être clairement indiqués.

Lorsque la fonction sans fil 5G fonctionnant en 5250-5350 MHz et 5470-5725 MHz est activée pour ce produit , il est nécessaire de porter une attention particulière aux choses suivantes.

Lorsque la fonction sans fil 5G fonctionnant en 5250-5350 MHz et 5470-5725 MHz est activée pour ce produit , il est nécessaire de porter une attention particulière aux choses suivantes.

- Pour les dispositifs munis d'antennes amovibles, le gain maximal d'antenne permis pour les dispositifs utilisant les bandes de 5 250 à 5 350 MHz et de 5 470 à 5 725 MHz doit être conforme à la limite de la p.i.r.e.

Industry Canada radiation exposure statement

This device complies with IC radiation exposure limits set forth for an uncontrolled environment. This device should be installed and operated with a minimum distance of 20 cm between the radiator and your body.

Déclaration d'exposition aux radiations:

Cet équipement est conforme aux limites d'exposition aux rayonnements IC établies pour un environnement non contrôlé. Cet équipement doit être installé et utilisé avec un minimum de 20 cm de distance entre la source de rayonnement et votre corps.

EUROPEAN UNION



The following information applies if you use the product within the European Union.

Declaration of Conformity with Regard to EU Directive 2014/53/EU (Radio Equipment Directive, RED)

- Compliance information for 2.4GHz and/or 5GHz wireless products relevant to the EU and other Countries following the EU Directive 2014/53/EU (RED). And this product may be used in all EU countries (and other countries following the EU Directive 2014/53/EU) without any limitation except for the countries mentioned below table:

- In the majority of the EU and other European countries, the 5GHz bands have been made available for the use of wireless local area networks (LANs). Later in this document you will find an overview of countries in which additional restrictions or requirements or both are applicable. The requirements for any country may evolve. Zyxel recommends that you check with the local authorities for the latest status of their national regulations for the 5GHz wireless LANs.
- If this device for operation in the band 5150-5350 MHz, it is for indoor use only.
- This equipment should be installed and operated with a minimum distance of 20cm between the radio equipment and your body.
- The maximum RF power operating for each band is as follows:
 - the band 2,400 to 2,483.5 MHz is 86.5 mW,
 - the bands 5,150 MHz to 5,350 MHz is 169.04 mW,
 - the 5,470 MHz to 5,725 MHz is 201.37 mW.

Български (Bulgarian)	<p>С настоящото Zyxel декларира, че това оборудване е в съответствие със съществените изисквания и другите приложими разпоредбите на Директива 12014/53/EC.</p> <p>National Restrictions</p> <ul style="list-style-type: none"> • The Belgian Institute for Postal Services and Telecommunications (BIPT) must be notified of any outdoor wireless link having a range exceeding 300 meters. Please check http://www.bipt.be for more details. • Draadloze verbindingen voor buitengebruik en met een reikwijdte van meer dan 300 meter dienen aangemeld te worden bij het Belgisch Instituut voor postdiensten en telecommunicatie (BIPT). Zie http://www.bipt.be voor meer gegevens. • Les liaisons sans fil pour une utilisation en extérieur d'une distance supérieure à 300 mètres doivent être notifiées à l'Institut Belge des services Postaux et des Télécommunications (IBPT). Visitez http://www.ibpt.be pour de plus amples détails.
Español (Spanish)	<p>Por medio de la presente Zyxel declara que el equipo cumple con los requisitos esenciales y cualesquiera otras disposiciones aplicables o exigibles de la Directiva 2014/53/UE.</p>
Čeština (Czech)	<p>Zyxel tímto prohlašuje, že tento zařazení je ve shodě se základními požadavky a dalšími příslušnými ustanoveními směrnice 2014/53/EU.</p>
Dansk (Danish)	<p>Undertegnede Zyxel erklærer herved, at følgende udstyr overholder de væsentlige krav og øvrige relevante krav i direktiv 2014/53/EU.</p> <p>National Restrictions</p> <ul style="list-style-type: none"> • In Denmark, the band 5150 - 5350 MHz is also allowed for outdoor usage. • I Danmark må frekvensbåndet 5150 - 5350 også anvendes udendørs.
Deutsch (German)	<p>Hiermit erklärt Zyxel, dass sich das Gerät Ausstattung in Übereinstimmung mit den grundlegenden Anforderungen und den übrigen einschlägigen Bestimmungen der Richtlinie 2014/53/EU befindet.</p>
Eesti keel (Estonian)	<p>Käesolevaga kinnitab Zyxel seadme seadme vastavust direktiivi 2014/53/EL põhinõuetele ja nimetatud direktiivist tulenevatele teistele asjakohastele sätetele.</p>
Ελληνικά (Greek)	<p>ΜΕ ΤΗΝ ΠΑΡΟΥΣΙΑ ΖΥΧΕΛ ΔΗΛΩΝΕΙ ΟΤΙ ΕΞΟΠΛΙΣΜΟΣ ΣΥΜΜΟΡΦΩΝΕΤΑΙ ΠΡΟΣ ΤΙΣ ΟΥΣΙΩΔΕΙΣ ΑΠΑΙΤΗΣΕΙΣ ΚΑΙ ΤΙΣ ΛΟΙΠΕΣ ΣΧΕΤΙΚΕΣ ΔΙΑΤΑΞΕΙΣ ΤΗΣ ΟΔΗΓΙΑΣ 2014/53/ΕΕ.</p>
English	<p>Hereby, Zyxel declares that this device is in compliance with the essential requirements and other relevant provisions of Directive 2014/53/EU.</p>
Français (French)	<p>Par la présente Zyxel déclare que l'appareil équipements est conforme aux exigences essentielles et aux autres dispositions pertinentes de la directive 2014/53/UE.</p>
Hrvatski (Croatian)	<p>Zyxel ovime izjavljuje da je radijska oprema tipa u skladu s Direktivom 2014/53/UE.</p>
Íslenska (Icelandic)	<p>Hér með lýsir, Zyxel því yfir að þessi búnaður er í samræmi við grunnkröfur og önnur viðeigandi ákvæði tilskipunar 2014/53/UE.</p>
Italiano (Italian)	<p>Con la presente Zyxel dichiara che questo attrezzatura è conforme ai requisiti essenziali ed alle altre disposizioni pertinenti stabilite dalla direttiva 2014/53/UE.</p> <p>National Restrictions</p> <ul style="list-style-type: none"> • This product meets the National Radio Interface and the requirements specified in the National Frequency Allocation Table for Italy. Unless this wireless LAN product is operating within the boundaries of the owner's property, its use requires a "general authorization." Please check http://www.sviluppoeconomico.gov.it/ for more details. <p>Questo prodotto è conforme alla specifiche di Interfaccia Radio Nazionali e rispetta il Piano Nazionale di ripartizione delle frequenze in Italia. Se non viene installato all'interno del proprio fondo, l'utilizzo di prodotti Wireless LAN richiede una "Autorizzazione Generale". Consultare http://www.sviluppoeconomico.gov.it/ per maggiori dettagli.</p>
Latviešu valoda (Latvian)	<p>Ar šo Zyxel deklarē, ka iekārtas atbilst Direktīvas 2014/53/ES būtiskajām prasībām un citiem ar to saistītajiem noteikumiem.</p> <p>National Restrictions</p> <ul style="list-style-type: none"> • The outdoor usage of the 2.4 GHz band requires an authorization from the Electronic Communications Office. Please check http://www.esd.lv for more details. • 2.4 GHz frekvenču joslas izmantošanai ārpus telpām nepieciešama atļauja no Elektronisko sakaru direkcijas. Vairāk informācijas: http://www.esd.lv.
Lietuvių kalba (Lithuanian)	<p>Šiuo Zyxel deklaruoja, kad šis įranga atitinka esminius reikalavimus ir kitas 2014/53/ES Direktyvos nuostatas.</p>
Magyar (Hungarian)	<p>Alulírott, Zyxel nyilatkozom, hogy a berendezés megfelel a vonatkozó alapvető követelményeknek és az 2014/53/EU irányelv egyéb előírásainak.</p>

Malti (Maltese)	Hawnhekk, Zyxel, jiddikjara li dan taghmir jikkonforma mal-htigijiet essenzjali u ma provvedimenti oħrajn relevanti li hemm fid-Dirrettiva 2014/53/UE.
Nederlands (Dutch)	Hierbij verklaart Zyxel dat het toestel uitrusting in overeenstemming is met de essentiële eisen en de andere relevante bepalingen van richtlijn 2014/53/EU.
Polski (Polish)	Niniejszym Zyxel oświadcza, że sprzęt jest zgodny z zasadniczymi wymogami oraz pozostałymi stosownymi postanowieniami Dyrektywy 2014/53/UE.
Português (Portuguese)	Zyxel declara que este equipamento está conforme com os requisitos essenciais e outras disposições da Directiva 2014/53/UE.
Română (Romanian)	Prin prezenta, Zyxel declară că acest echipament este în conformitate cu cerințele esențiale și alte prevederi relevante ale Directivei 2014/53/UE.
Slovenčina (Slovak)	Zyxel týmto vyhlasuje, že zariadenia spĺňa základné požiadavky a všetky príslušné ustanovenia Smernice 2014/53/EÚ.
Slovenščina (Slovene)	Zyxel izjavlja, da je ta oprema v skladu z bistvenimi zahtevami in ostalimi relevantnimi določili direktive 2014/53/EU.
Suomi (Finnish)	Zyxel vakuuttaa täten että laitteen tyyppinen laite on direktiivin 2014/53/EU oleellisten vaatimusten ja sitä koskevien direktiivin muiden ehtojen mukainen.
Svenska (Swedish)	Härmed intygar Zyxel att denna utrustning står i överensstämmelse med de väsentliga egenskapskrav och övriga relevanta bestämmelser som framgår av direktiv 2014/53/EU.
Norsk (Norwegian)	Erklærer herved Zyxel at dette utstyret er i samsvar med de grunnleggende kravene og andre relevante bestemmelser i direktiv 2014/53/EU.

-
- Notes:
1. Although Norway, Switzerland and Liechtenstein are not EU member states, the EU Directive 2014/53/EU has also been implemented in those countries.
 2. The regulatory limits for maximum output power are specified in EIRP. The EIRP level (in dBm) of a device can be calculated by adding the gain of the antenna used (specified in dBi) to the output power available at the connector (specified in dBm).

List of national codes

COUNTRY	ISO 3166 2 LETTER CODE	COUNTRY	ISO 3166 2 LETTER CODE
Austria	AT	Liechtenstein	LI
Belgium	BE	Lithuania	LT
Bulgaria	BG	Luxembourg	LU
Croatia	HR	Malta	MT
Cyprus	CY	Netherlands	NL
Czech Republic	CZ	Norway	NO
Denmark	DK	Poland	PL
Estonia	EE	Portugal	PT
Finland	FI	Romania	RO
France	FR	Serbia	RS
Germany	DE	Slovakia	SK
Greece	GR	Slovenia	SI
Hungary	HU	Spain	ES
Iceland	IS	Switzerland	CH
Ireland	IE	Sweden	SE
Italy	IT	Turkey	TR
Latvia	LV	United Kingdom	GB

Safety Warnings

- Do not use this product near water, for example, in a wet basement or near a swimming pool.
- Do not expose your device to dampness, dust or corrosive liquids.
- Do not store things on the device.
- Do not obstruct the device ventilation slots as insufficient airflow may harm your device. For example, do not place the device in an enclosed space such as a box or on a very soft surface such as a bed or sofa.
- Do not install, use, or service this device during a thunderstorm. There is a remote risk of electric shock from lightning.
- Connect ONLY suitable accessories to the device.
- Do not open the device or unit. Opening or removing covers can expose you to dangerous high voltage points or other risks. ONLY qualified service personnel should service or disassemble this device. Please contact your vendor for further information.

- Make sure to connect the cables to the correct ports.
- Place connecting cables carefully so that no one will step on them or stumble over them.
- Always disconnect all cables from this device before servicing or disassembling.
- Do not remove the plug and connect it to a power outlet by itself; always attach the plug to the power adaptor first before connecting it to a power outlet.
- Do not allow anything to rest on the power adaptor or cord and do NOT place the product where anyone can walk on the power adaptor or cord.
- Please use the provided or designated connection cables/power cables/ adaptors. Connect it to the right supply voltage (for example, 110V AC in North America or 230V AC in Europe). If the power adaptor or cord is damaged, it might cause electrocution. Remove it from the device and the power source, repairing the power adapter or cord is prohibited. Contact your local vendor to order a new one.
- Do not use the device outside, and make sure all the connections are indoors. There is a remote risk of electric shock from lightning.
- CAUTION: Risk of explosion if battery is replaced by an incorrect type, dispose of used batteries according to the instruction. Dispose them at the applicable collection point for the recycling of electrical and electronic devices. For detailed information about recycling of this product, please contact your local city office, your household waste disposal service or the store where you purchased the product.
- The following warning statements apply, where the disconnect device is not incorporated in the device or where the plug on the power supply cord is intended to serve as the disconnect device,
 - For permanently connected devices, a readily accessible disconnect device shall be incorporated external to the device;
 - For pluggable devices, the socket-outlet shall be installed near the device and shall be easily accessible.

Environment Statement

ErP (Energy-related Products)

Zyxel products put on the EU market in compliance with the requirement of the European Parliament and the Council published Directive 2009/125/EC establishing a framework for the setting of ecodesign requirements for energy-related products (recast), so called as "ErP Directive (Energy-related Products directive) as well as ecodesign requirement laid down in applicable implementing measures, power consumption has satisfied regulation requirements which are:

- Network standby power consumption < 8W, and/or
- Off mode power consumption < 0.5W, and/or
- Standby mode power consumption < 0.5W.

(Wireless setting, please refer to "Wireless" chapter for more detail.)

European Union - Disposal and Recycling Information

The symbol below means that according to local regulations your product and/or its battery shall be disposed of separately from domestic waste. If this product is end of life, take it to a recycling station designated by local authorities. At the time of disposal, the separate collection of your product and/or its battery will help save natural resources and ensure that the environment is sustainable development.

Die folgende Symbol bedeutet, dass Ihr Produkt und/oder seine Batterie gemäß den örtlichen Bestimmungen getrennt vom Hausmüll entsorgt werden muss. Wenden Sie sich an eine Recyclingstation, wenn dieses Produkt das Ende seiner Lebensdauer erreicht hat. Zum Zeitpunkt der Entsorgung wird die getrennte Sammlung von Produkt und/oder seiner Batterie dazu beitragen, natürliche Ressourcen zu sparen und die Umwelt und die menschliche Gesundheit zu schützen.

El símbolo de abajo indica que según las regulaciones locales, su producto y/o su batería deberán depositarse como basura separada de la doméstica. Cuando este producto alcance el final de su vida útil, llévelo a un punto limpio. Cuando llegue el momento de desechar el producto, la recogida por separado éste y/o su batería ayudará a salvar los recursos naturales y a proteger la salud humana y medioambiental.

Le symbole ci-dessous signifie que selon les réglementations locales votre produit et/ou sa batterie doivent être éliminés séparément des ordures ménagères. Lorsque ce produit atteint sa fin de vie, amenez-le à un centre de recyclage. Au moment de la mise au rebut, la collecte séparée de votre produit et/ou de sa batterie aidera à économiser les ressources naturelles et protéger l'environnement et la santé humaine.

Il simbolo sotto significa che secondo i regolamenti locali il vostro prodotto e/o batteria deve essere smaltito separatamente dai rifiuti domestici. Quando questo prodotto raggiunge la fine della vita di servizio portarlo a una stazione di riciclaggio. Al momento dello smaltimento, la raccolta separata del vostro prodotto e/o della sua batteria aiuta a risparmiare risorse naturali e a proteggere l'ambiente e la salute umana.

Symbolen innebär att enligt lokal lagstiftning ska produkten och/eller dess batteri kastas separat från hushållsavfallet. När den här produkten når slutet av sin livslängd ska du ta den till en återvinningsstation. Vid tiden för kasseringen bidrar du till en bättre miljö och mänsklig hälsa genom att göra dig av med den på ett återvinningsställe.



台灣



以下訊息僅適用於產品具有無線功能且銷售至台灣地區

- 第十二條 經型式認證合格之低功率射頻電機，非經許可，公司，商號或使用者均不得擅自變更頻率、加大功率或變更原設計之特性及功能。
- 第十四條 低功率射頻電機之使用不得影響飛航安全及干擾合法通信；經發現有干擾現象時，應立即停用，並改善至無干擾時方得繼續使用。前項合法通信，指依電信法規定作業之無線電通信。低功率射頻電機須忍受合法通信或工業、科學及醫療用電波輻射性電機設備之干擾。
- 無線資訊傳輸設備須忍受合法通信之干擾且不得干擾合法通信；如造成干擾，應立即停用，俟無干擾之虞，始得繼續使用。
- 無線資訊傳輸設備的製造廠商應確保頻率穩定性，如依製造廠商使用手冊上所述正常操作，發射的信號應維持於操作頻帶中。
- 使用無線產品時，應避免影響附近雷達系統之操作。
- 若使用高增益指向性天線，該產品僅應用於固定式點對點系統。
-

以下訊息僅適用於產品屬於專業安裝並銷售至台灣地區

- 本器材須經專業工程人員安裝及設定，始得設置使用，且不得直接販售給一般消費者。





安全警告 - 為了您的安全，請先閱讀以下警告及指示：

- 請勿將此產品接近水、火焰或放置在高溫的環境。
- 避免設備接觸：
 - 任何液體 - 切勿讓設備接觸水、雨水、高濕度、污水腐蝕性的液體或其他水份。
 - 灰塵及污物 - 切勿接觸灰塵、污物、沙土、食物或其他不合適的材料。
- 雷雨天氣時，不要安裝，使用或維修此設備。有遭受電擊的風險。
- 切勿重摔或撞擊設備，並勿使用不正確的電源變壓器。
- 若接上不正確的電源變壓器會有爆炸的風險。
- 請勿隨意更換產品內的電池。
- 如果更換不正確之電池型式，會有爆炸的風險，請依製造商說明書處理使用過之電池。
- 請將廢電池丟棄在適當的電器或電子設備回收處。
- 請勿將設備解體。
- 請勿阻礙設備的散熱孔，空氣對流不足將會造成設備損害。
- 請插在正確的電壓供給插座（如：北美 / 台灣電壓 110V AC，歐洲是 230V AC）。
- 假若電源變壓器或電源變壓器的纜線損壞，請從插座拔除，若您還繼續插電使用，會有觸電死亡的風險。
- 請勿試圖修理電源變壓器或電源變壓器的纜線，若有毀損，請直接聯絡您購買的店家，購買一個新的電源變壓器。
- 請勿將此設備安裝於室外，此設備僅適合放置於室內。
- 請勿隨一般垃圾丟棄。
- 請參閱產品背貼上的設備額定功率。
- 請參考產品型錄或是彩盒上的作業溫度。
- 產品沒有斷電裝置或者採用電源線的插頭視為斷電裝置的一部分，以下警語將適用：
 - 對永久連接之設備，在設備外部須安裝可觸及之斷電裝置
 - 對插接式之設備，插座必須接近安裝之地點而且是易於觸及的。

About the Symbols

Various symbols are used in this product to ensure correct usage, to prevent danger to the user and others, and to prevent property damage. The meaning of these symbols are described below. It is important that you read these descriptions thoroughly and fully understand the contents.

Explanation of the Symbols

SYMBOL	EXPLANATION
	Alternating current (AC): AC is an electric current in which the flow of electric charge periodically reverses direction.
	Direct current (DC): DC is the unidirectional flow or movement of electric charge carriers.
	Earth; ground: A wiring terminal intended for connection of a Protective Earthing Conductor.
	Class II equipment: The method of protection against electric shock in the case of class II equipment is either double insulation or reinforced insulation.

Viewing Certifications

Go to <http://www.zyxel.com> to view this product's documentation and certifications.

Zyxel Limited Warranty

Zyxel warrants to the original end user (purchaser) that this product is free from any defects in material or workmanship for a specific period (the Warranty Period) from the date of purchase. The Warranty Period varies by region. Check with your vendor and/or the authorized Zyxel local distributor for details about the Warranty Period of this product. During the warranty period, and upon proof of purchase, should the product have indications of failure due to faulty workmanship and/or materials, Zyxel will, at its discretion, repair or replace the defective products or components without charge for either parts or labor, and to whatever extent it shall deem necessary to restore the product or components to proper operating condition. Any replacement will consist of a new or re-manufactured functionally equivalent product of equal or higher value, and will be solely at the discretion of Zyxel. This warranty shall not apply if the product has been modified, misused, tampered with, damaged by an act of God, or subjected to abnormal working conditions.

Note

Repair or replacement, as provided under this warranty, is the exclusive remedy of the purchaser. This warranty is in lieu of all other warranties, express or implied, including any implied warranty of merchantability or fitness for a particular use or purpose. Zyxel shall in no event be held liable for indirect or consequential damages of any kind to the purchaser.

To obtain the services of this warranty, contact your vendor. You may also refer to the warranty policy for the region in which you bought the device at http://www.zyxel.com/web/support_warranty_info.php.

Registration

Register your product online to receive e-mail notices of firmware upgrades and information at www.zyxel.com for global products, or at www.us.zyxel.com for North American products.

Open Source Licenses

This product contains in part some free software distributed under GPL license terms and/or GPL like licenses. Open source licenses are provided with the firmware package. You can download the latest firmware at www.zyxel.com. To obtain the source code covered under those Licenses, please contact support@zyxel.com.tw to get it.

Index

A

AP

- automatic selection [48](#)
- configuring [48, 49](#)
- connection [47](#)
- manual selection [49](#)

AP Mode

- menu [23, 28](#)
- status screen [21, 27, 31](#)

AP mode

- scheduling [74](#)
- setting up [21, 26](#)

B

- backup configuration [88](#)

C

- certifications [107](#)
 - viewing [110](#)
- channel [22, 23, 33](#)
- configuration
 - backup [88](#)
 - reset factory defaults [89](#)
 - restore [88](#)
- connection
 - AP [47](#)
- contact information [98](#)
- copyright [104](#)
- CPU usage [23, 28, 33](#)
- customer support [98](#)

D

- Daylight saving [85](#)

- disclaimer [104](#)
- duplex setting [23, 33](#)

E

- encryption [57](#)
 - key [58](#)

F

- factory defaults
 - restore [89](#)
- file sharing
 - FTP [80](#)
- firmware upgrade
 - screen [85](#)
- firmware upload [85](#)
 - file extension
 - using HTTP
- firmware version [22, 27, 32](#)

G

- general [82](#)
- general wireless LAN screen [58](#)

I

- Internet
 - connection [47](#)
- IP Address [79](#)

L

- LAN [78](#)
- LAN IP
 - screen [78](#)
- LAN setup [78](#)
- language [89](#)
- link type [23, 33](#)
- logout
 - Web Configurator [17](#)

M

- MAC [69](#)
- MAC address [57](#)
- MAC address filtering [69](#)
- MAC address list [57, 69](#)
- managing the device
 - good habits [9](#)
- media access control [69](#)
- memory usage [23, 28, 33](#)
- mode
 - access point [18](#)
 - normal [91](#)
 - range boost [91](#)
 - speed boost [91](#)
 - universal repeater [18](#)

N

- navigation
 - panel [23, 28, 34](#)
- navigation panel [23, 28, 34](#)
- normal mode [91](#)

O

- operating
 - mode [19](#)
- operating mode
 - changing [19](#)

- normal [91](#)
- range boost [91](#)
- speed boost [91](#)

P

- PIN
 - configuration [45, 46](#)
- port speed [23, 33](#)
- push button
 - configuration [44, 45](#)

R

- range boost mode [91](#)
- reset the device [97](#)
- restore configuration [88](#)
- RTS/CTS threshold [70](#)

S

- scheduling [74](#)
 - wireless LAN [74](#)
- security
 - PBC [44, 45](#)
 - PIN [45, 46](#)
 - WPS [44](#)
- service set identification [66](#)
- service set identity. *see* SSID.
- speed boost mode [91](#)
- SSID [22, 23, 33, 56, 66](#)
- subnet mask [79](#)
- Summary
 - Packet statistics [54](#)
- system [82](#)
 - WPS behavior [90](#)
- system mode [89](#)
 - normal [91](#)
 - range boost [91](#)
 - speed boost [91](#)
- system password
 - screen [83](#)

T

Time setting [83](#)

W

warranty [110](#)

note [110](#)

web configurator

accessing [13](#)

overview [13](#)

WEP Encryption [61](#), [63](#), [64](#)

WEP encryption [62](#)

WEP key [62](#)

wireless channel [96](#)

wireless LAN [96](#)

wireless network [57](#)

basic guidelines [56](#)

encryption [57](#)

security [57](#)

SSID [56](#)

wireless security [57](#)

overview [57](#)

troubleshooting [96](#)

type [57](#)

wireless tutorial [44](#)

wizard setup [36](#)

WPS [71](#)

behavior [90](#)

screen [71](#)

WPS button [12](#), [97](#)